

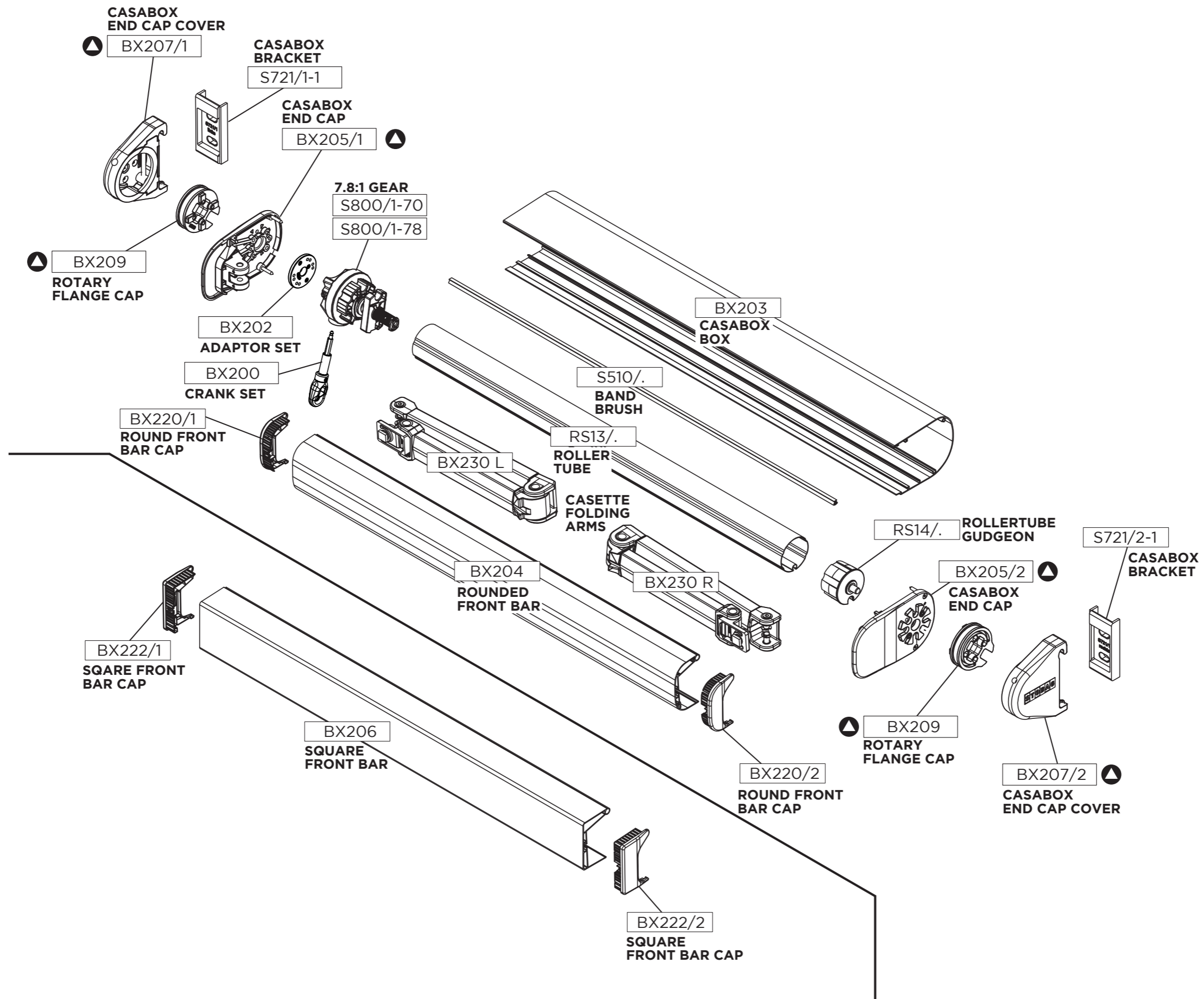

STOBAG CAMABOX

CRANK OPERATED FULL CASSETTE FOLDING ARM AWNING SYSTEM

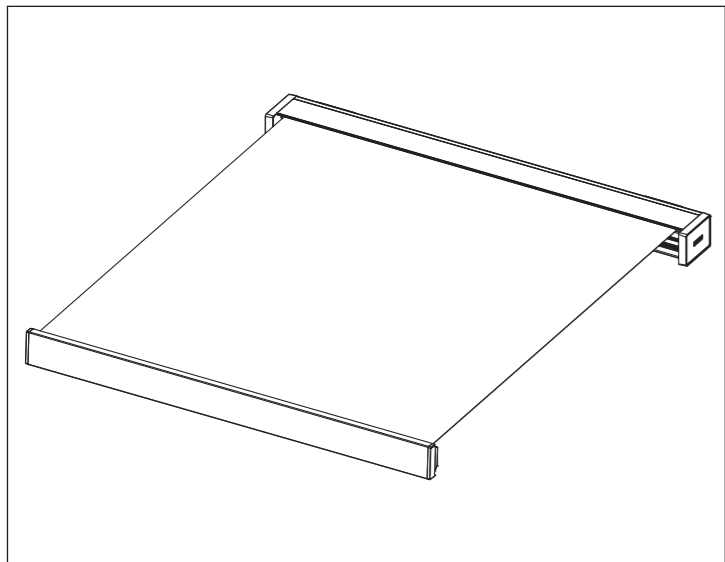



BX4000
 Art. 258121 V02 2017-06-27
 © STOBAG AG www.stobag.com

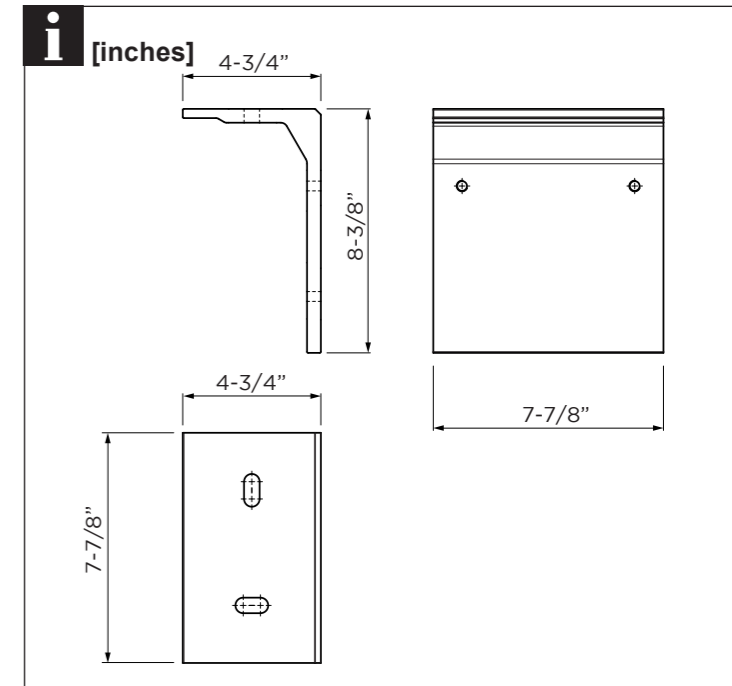
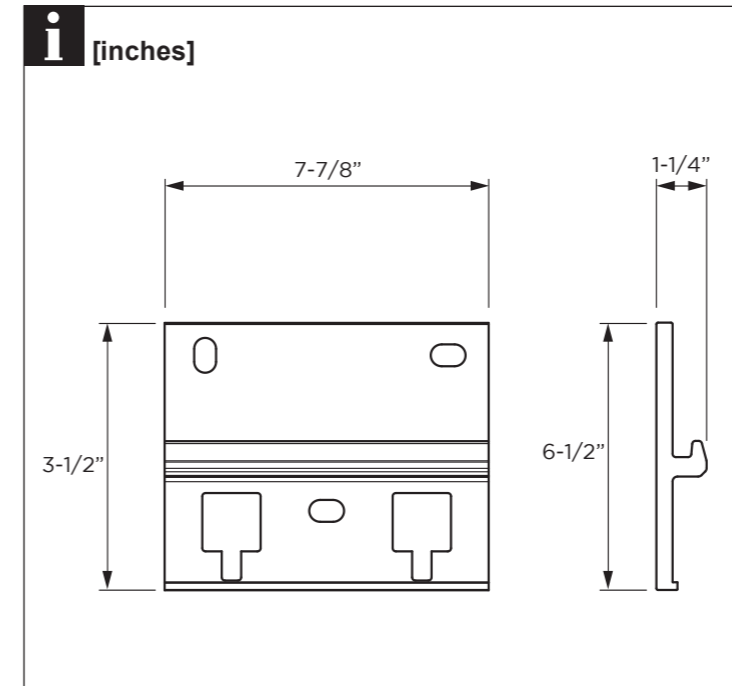
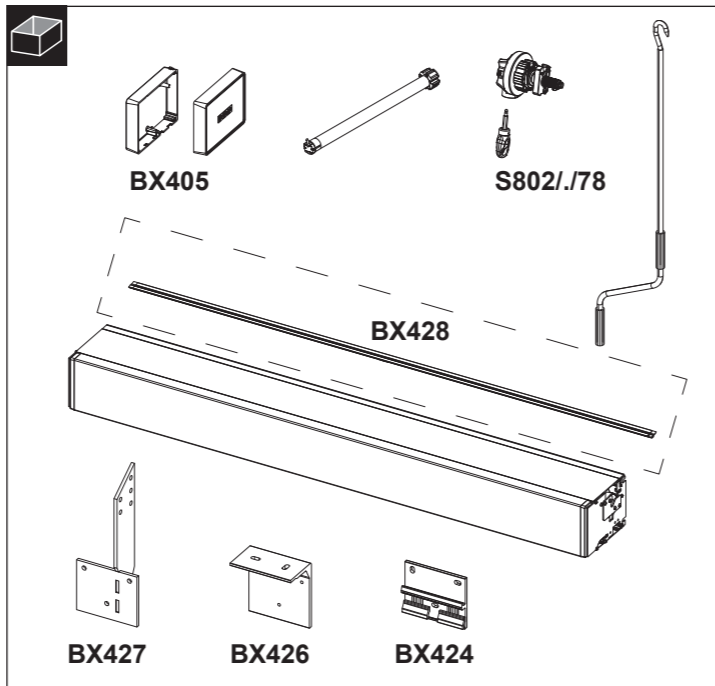

EN 13561:2004+A1:2008

INSTALLATION IS ONLY TO BE CARRIED OUT BY TRAINED SPECIALISTS. IT IS EXTREMELY IMPORTANT THAT THE SAFETY INSTRUCTIONS IN THE OPERATING MANUAL BE FOLLOWED.

