

B500-ODL

# HOLIDAY AT HOME

Mounting instructions



OUTDOOR LIVING by  
**BRUSTOR** 

[www.brustor.com](http://www.brustor.com)  
EN V2016.00

<b>01</b>	<b>0. OVERVIEW</b>
<b>02</b>	<b>1. PLACING THE SUPPORTS</b>
<b>03</b>	<b>2. PLACING THE VERTICAL POLES</b>
<b>04</b>	<b>3. PLACING THE MAINHOUSINGS</b>
<b>06</b>	<b>4. ADJUSTING THE CONSTRUCTION</b>
06	4.a Levelness
06	4.b Perpendicularity
<b>07</b>	<b>5. ASSEMBLY ARMS</b>
07	5.a Preparation
08	5.b Fitting wall brackets
09	5.c Assembly arms & rollertube
<b>12</b>	<b>6. FIXATION MOTOR</b>
<b>13</b>	<b>7. ASSEMBLY FOLDING FABRIC</b>
<b>14</b>	<b>8. PLACING THE RAINGUTTERS</b>
<b>14</b>	<b>9. SCREENS</b>
14	9.a Rollertubes
14	9.b Motor cable
<b>17</b>	<b>10. SCREEN GUIDES</b>
17	10.a Leadrail
17	10.b PVC guide
<b>18</b>	<b>11. ADJUSTING THE ENDPOINTS</b>
<b>19</b>	<b>12. CONNECTIONS DIAGRAM</b>
<b>19</b>	<b>13. FINISHING</b>
19	13.a Cover mainhousing
19	13.b Cover poles
20	13.c Cover plate bottom arm
20	13.d Fabric fixation profile
21	13.e Fitting sealing rubbers
21	13.f Triangular screen
22	13.g Mounting sideplates
23	13.h Endcap hinge
23	13.i Roof covers
<b>25</b>	<b>14. FITTING MODULES AGAINST EACH OTHER</b>

# 0. OVERVIEW

› Check that all parts are present and the dimensions correspond to the order

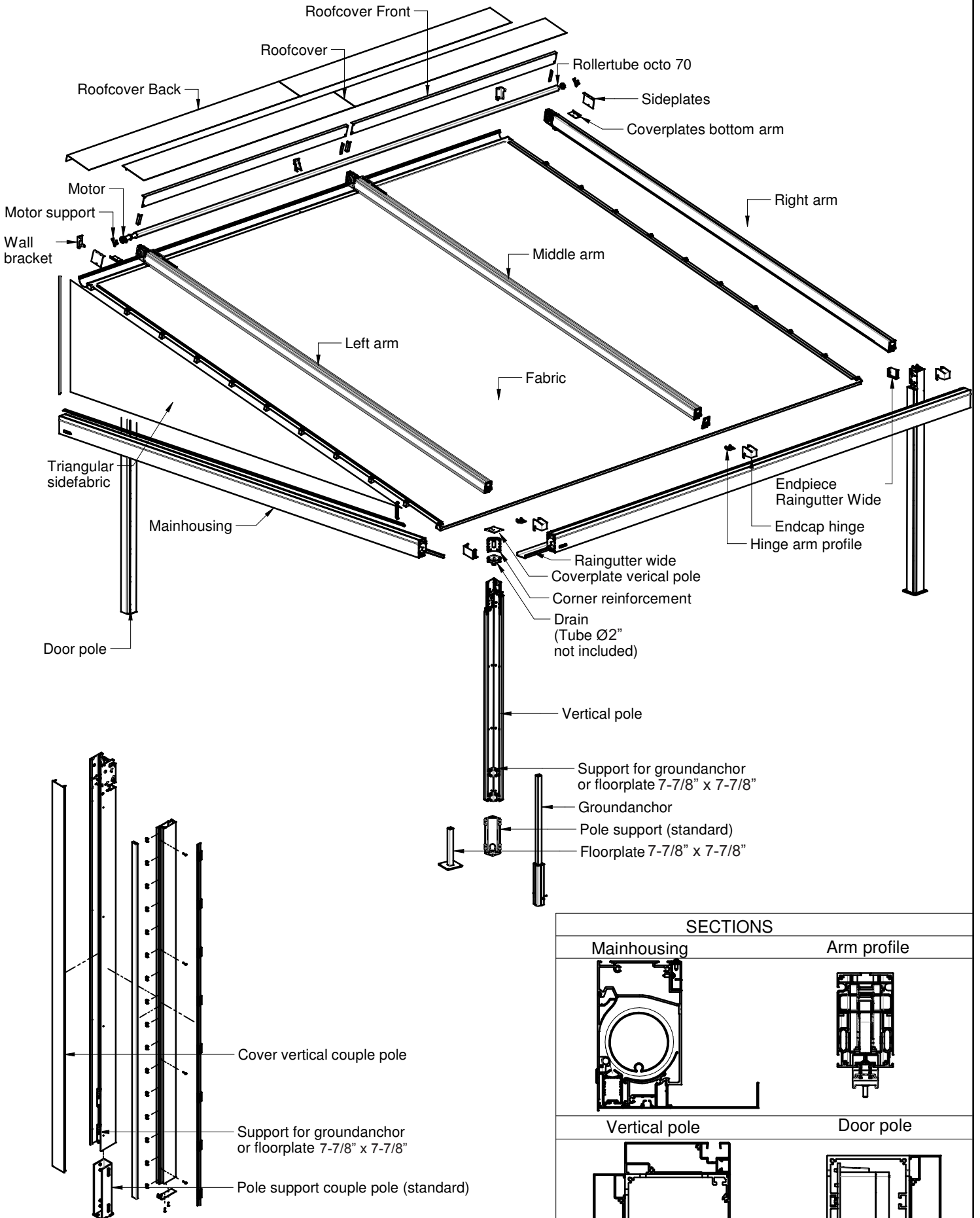

## SECTIONS

Mainhousing

Arm profile

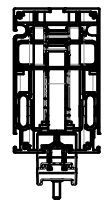
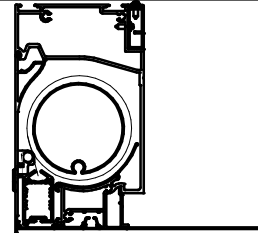

Vertical pole

Door pole

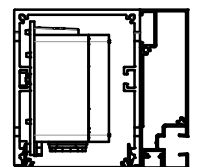
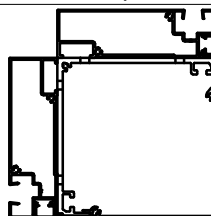

# 1. PLACING THE SUPPORTS

- › Place the ground fixation according to the drawing below.
- › Check the fixation by measuring diagonally - the difference may be no more than 5mm.

No screens on L1 or L2

Pole Support

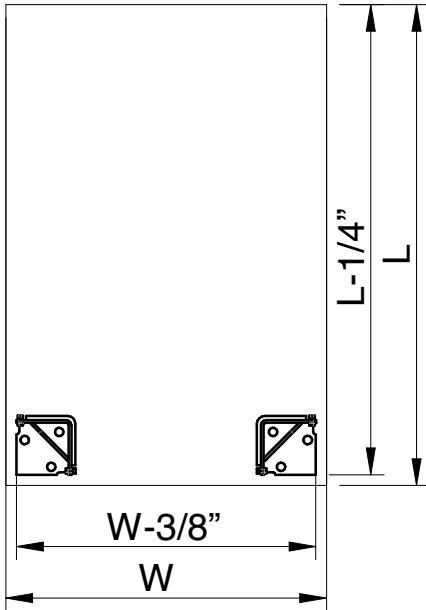

Ground Anchor

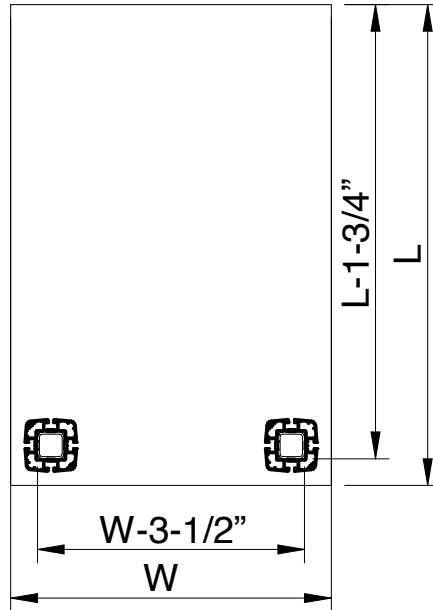

Floorplate 7-7/8" x7-7/8"

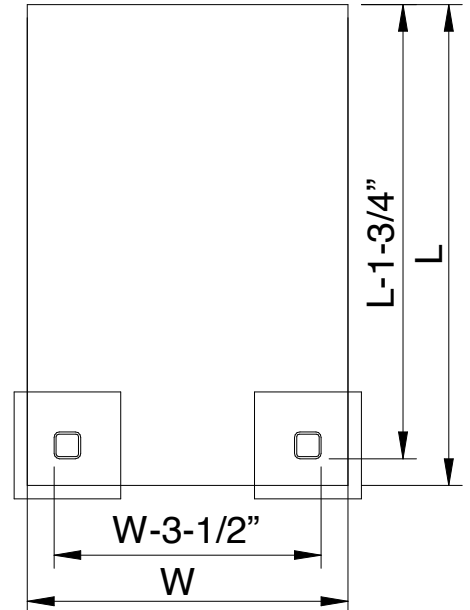

Screens on L1 and/or L2

Pole Support

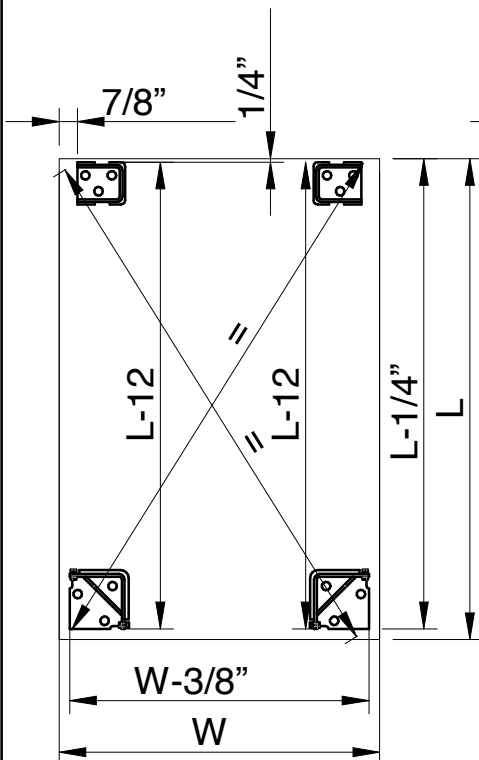

Ground Anchor

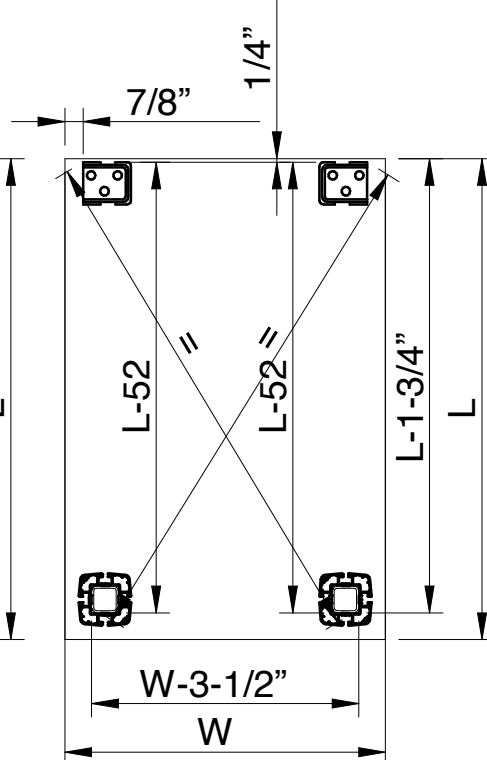

Floorplate 20x20

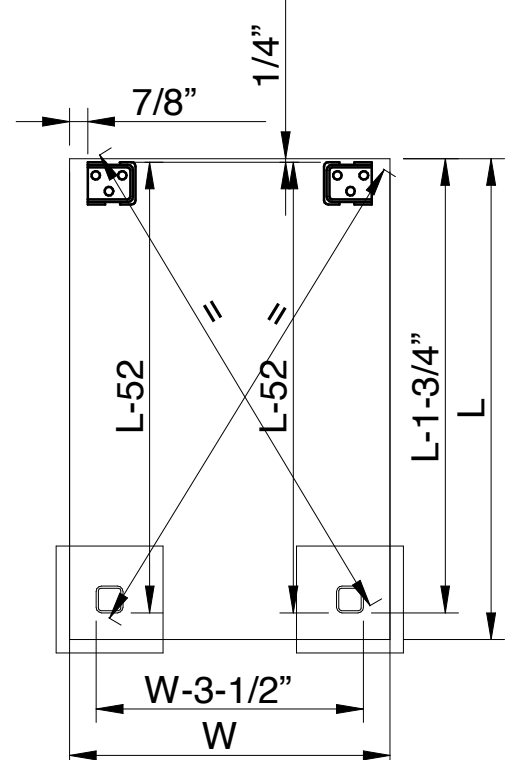

## 2. PLACING THE VERTICAL POLES

- › Take the pole supports out of the vertical poles, also remove the pre-assembled zip guides and the corner reinforcement (1).
- › Fix the pole supports or the floor plates on the ground.
- › Check the dimensions on the previous page again before fixing the bolts.
- › Then slide the vertical pole (possibly provided with screen guides) on top.
- › Make sure that the pole is perpendicular.
- › Level any unevenness.
- › Note the difference between a pole where a screen will be fitted to the side (2) and where no side screen will be fitted (3).
- › Place the poles as shown below.

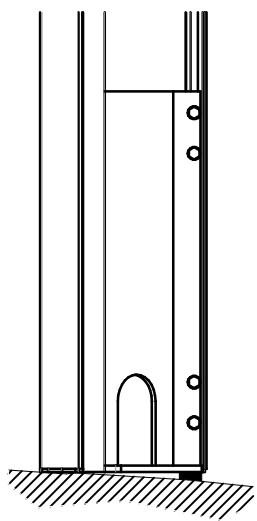
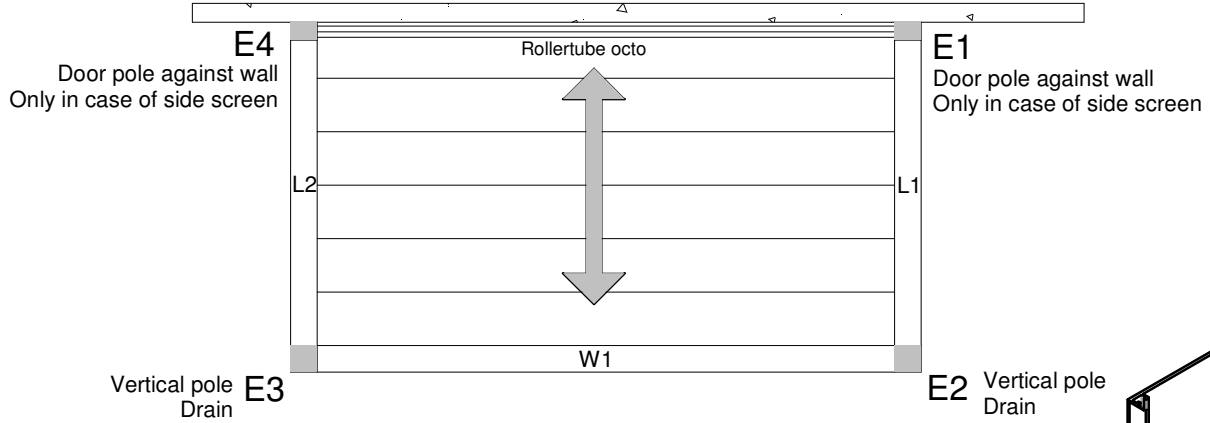

Pole support

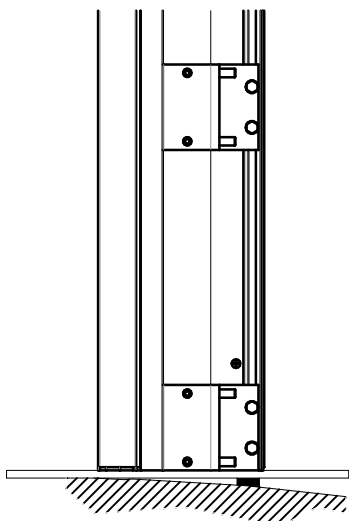

Floor plate 7-7/8" x 7-7/8"  
Ground anchor

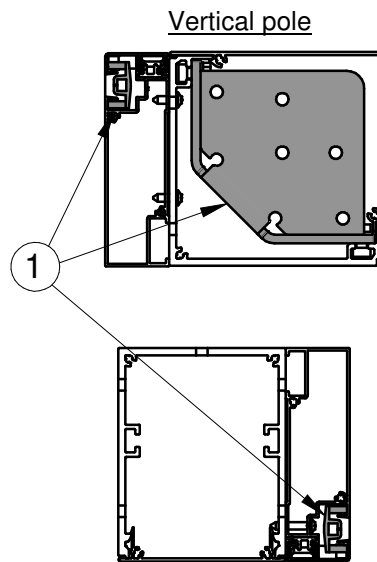

Door pole against the well

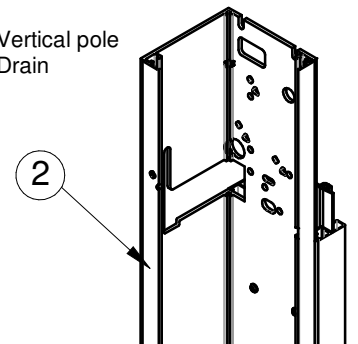

Vertical pole without side screen

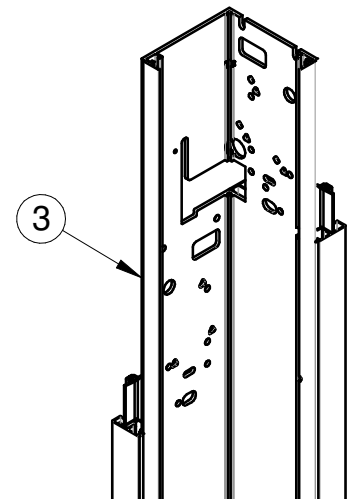

Vertical pole with side screen

- › Place a drain in post E2 and E3 (poles at the front).

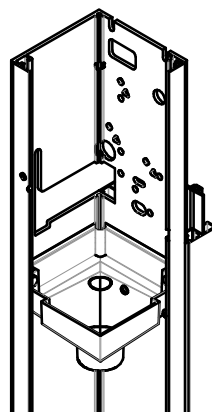
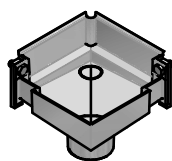

### 3. PLACING THE MAINHOUSINGS

#### Side W1

- › Take the screens out of the main housings
- › Fit the 2 upper screws (6.3x50) on both sides of the main housings.
- › Turn them to 10 mm from the end.

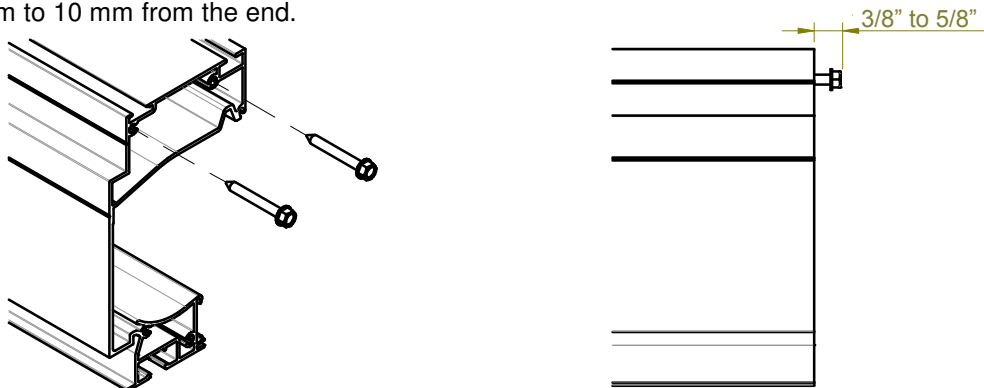

- › Slide the main housings over the vertical poles(1)
- › Screw both screws fully in.
- › Do the same with the bottom screws (2).

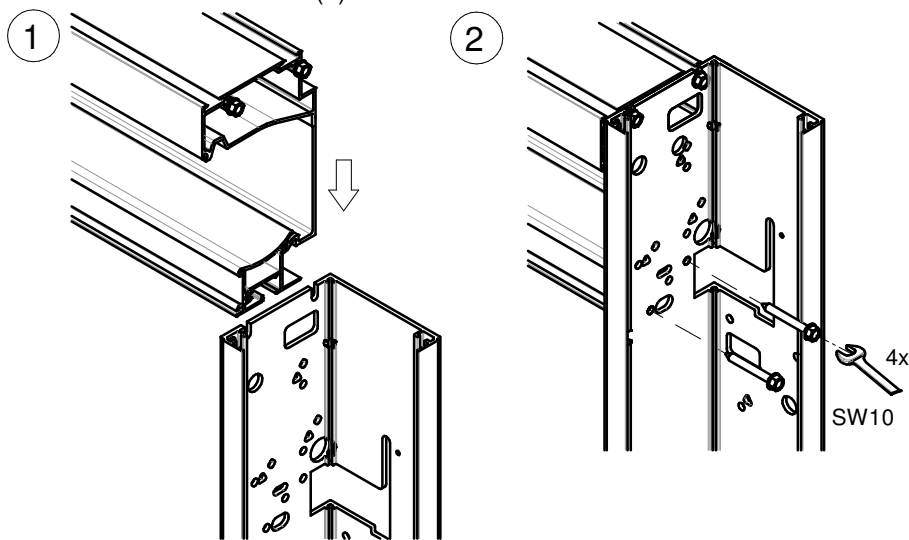

#### L1 AND L2 SIDE ( in the case of side screen)

- › Fit a screw on the side of the door pole (6.3x50) + 1 x M6 x 40
- › Turn them to 10 mm from the end.
- › Slide the screen housings over the door profile. (1)
- › Fully tighten the screw 6.3x50.
- › Do the same with the two bottom screws (6.3x50) . (2)
- › Fix the door profile to the wall with appropriate fixing material. (3)
- › Fasten the coverplate on the door profile with 2 screws (4.2 x 19) (4)

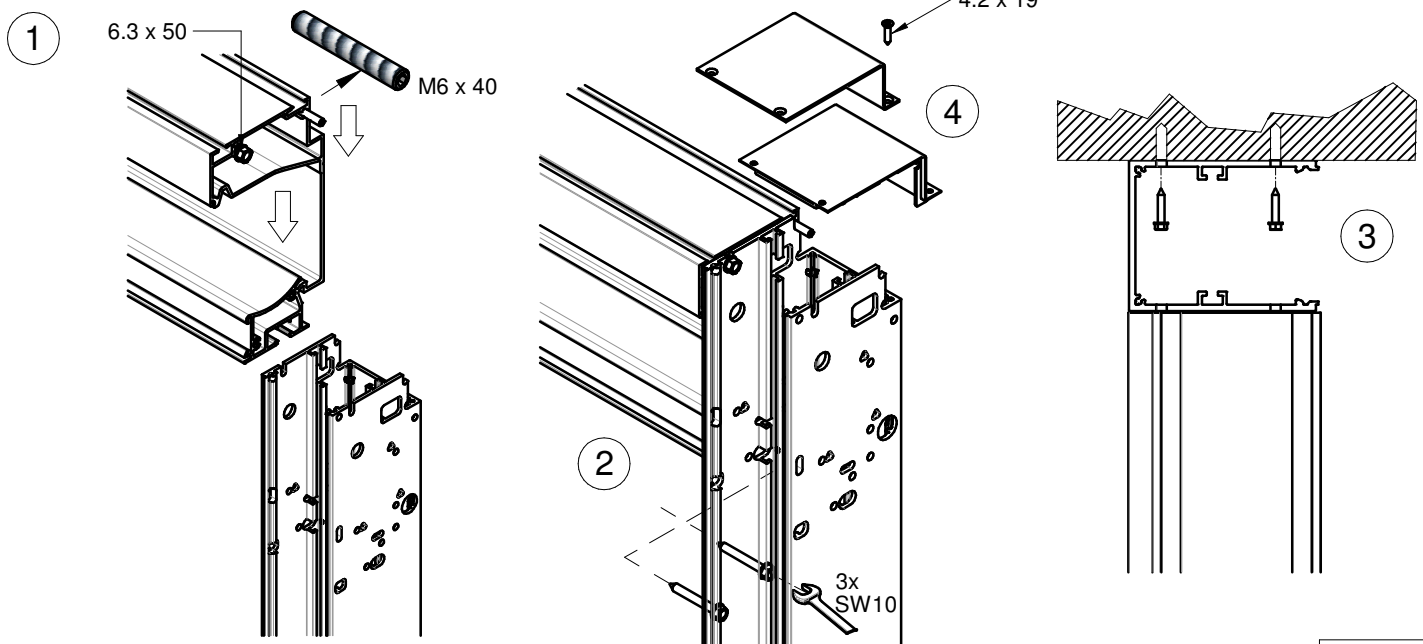

## SIDE WITH DOOR PROFILE

- › Take the screens out of the main housings.
- › Fit 1 screw on the side of the door profile (6.3x50) + 1 x M6 x 40.
- › Turn them to 3/8" from the end.
- › Slide the main housings over the door pole (1).
- › Fully tighten the screw 6.3x50.
- › Do the same with the bottom screws (2).
- › Fasten the coverplate on the door profile with 2 screws (4.2x19) (3).

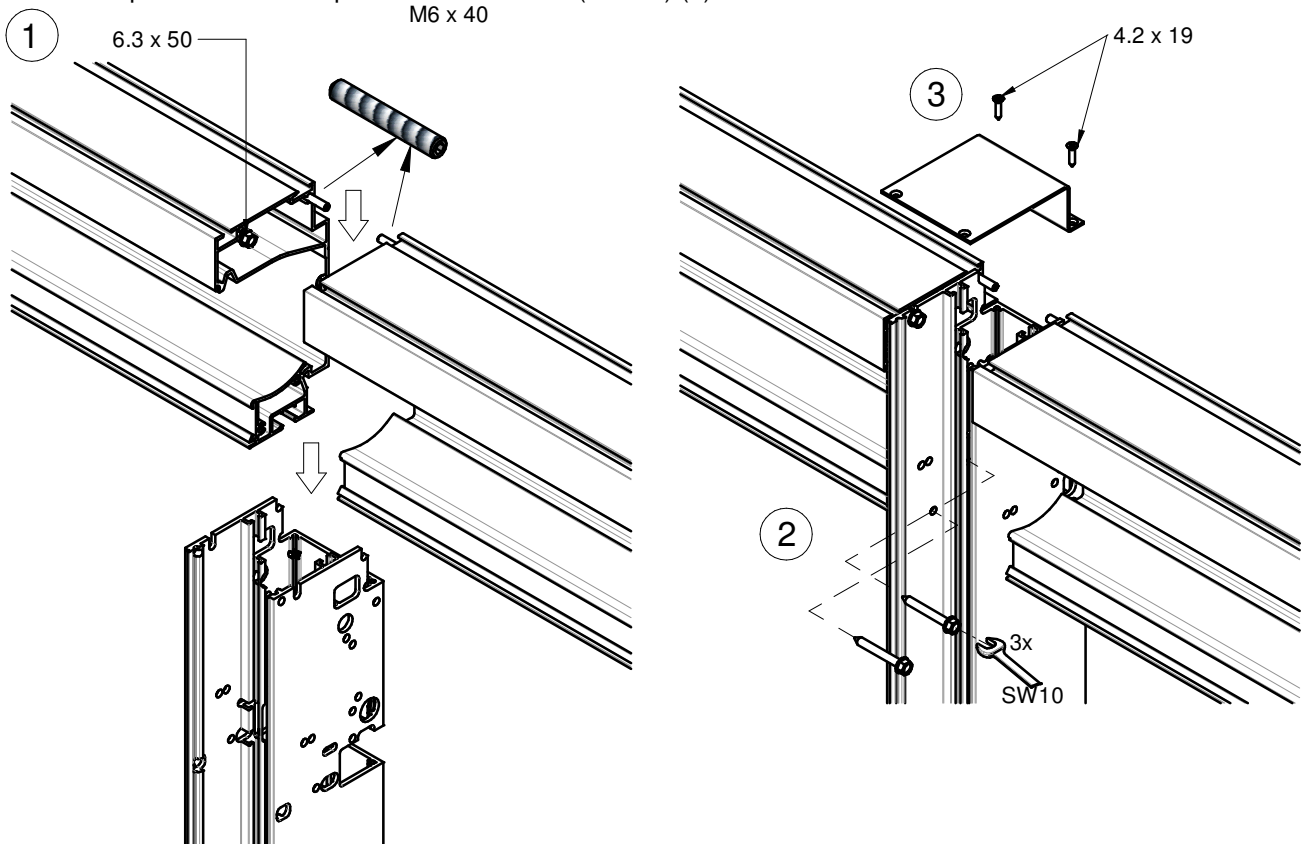

- › With beam L1 and L2 (and if a door profile was provided on the W1 side) a filler profile + cover is supplied.
- › Place these as shown on the drawings below.
- › Fix with self-tapping screws (1) close off the profile with the cover.
- › Fix the cover with three screws (2).

### Assembly filler profile on L1 and L2

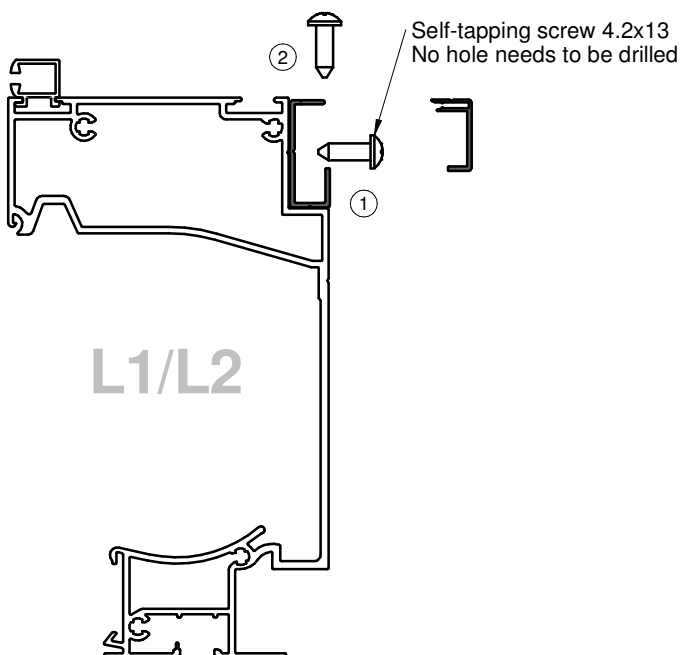

### Assembly filler profile on W1

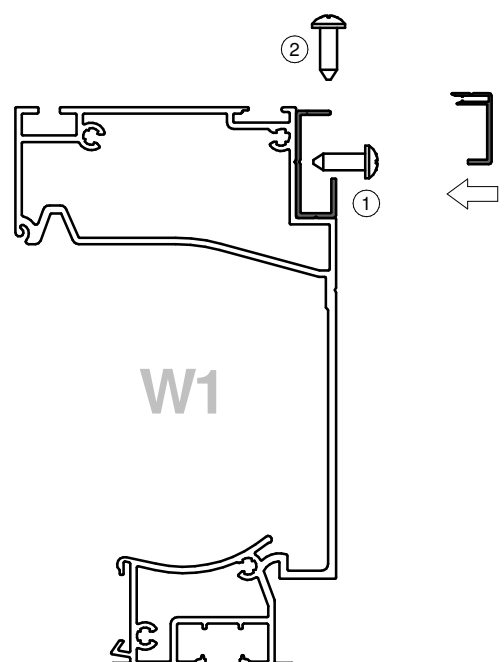

## 4 ADJUSTING THE CONSTRUCTION

### 4.a LEVELNESS

- › Use a spirit level or laser to check the levelness of the top side of the construction.

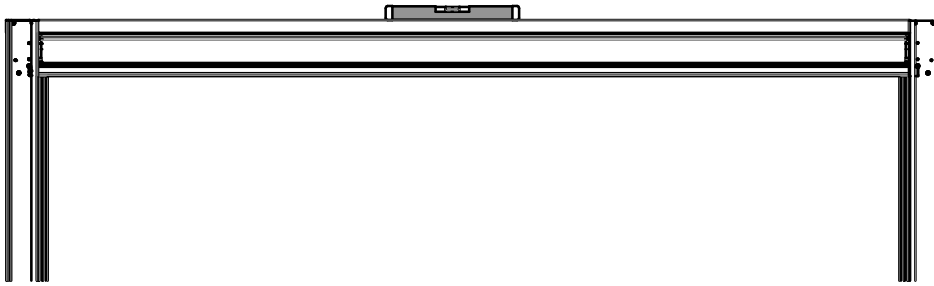

- › Adjust the construction if necessary
- › Slide the poles upwards until the top of the construction is completely level.
- › Temporarily place a filler piece under the poles if necessary.

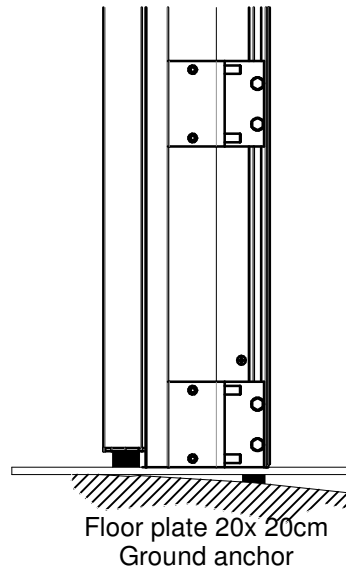
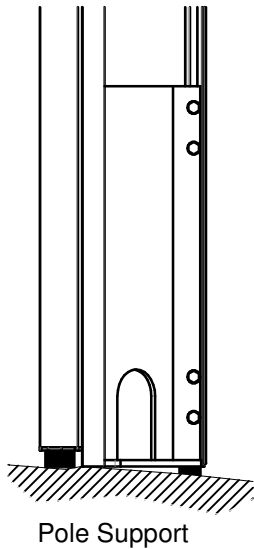

### 4.b PERPENDICULARITY

- › Check the perpendicularity with the measurements below ( $L1 \pm 2\text{mm}$ !).
- › Also check the diagonals on the top side.
- › Further adjust the pole supports a little if necessary.

Side view

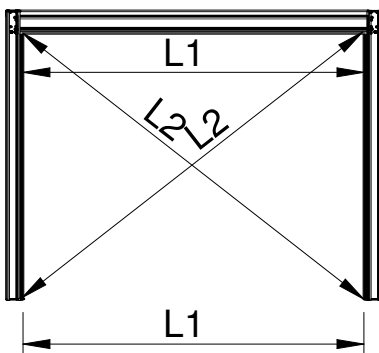

Top view

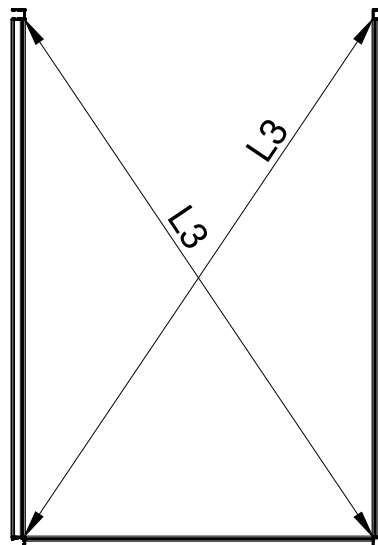

- › When everything has been adjusted, firmly tighten all bolts.
- › Remove any filler pieces used.



## 5. ASSEMBLY ARMS

### 5.a PREPARATION

#### 1. Place the coverplates

- › Fit a corner reinforcement in post E2 and E3 (poles at the front) (1).
- › Place the coverplates on the poles E2 and E3 (2) and only screw tight in the corner.

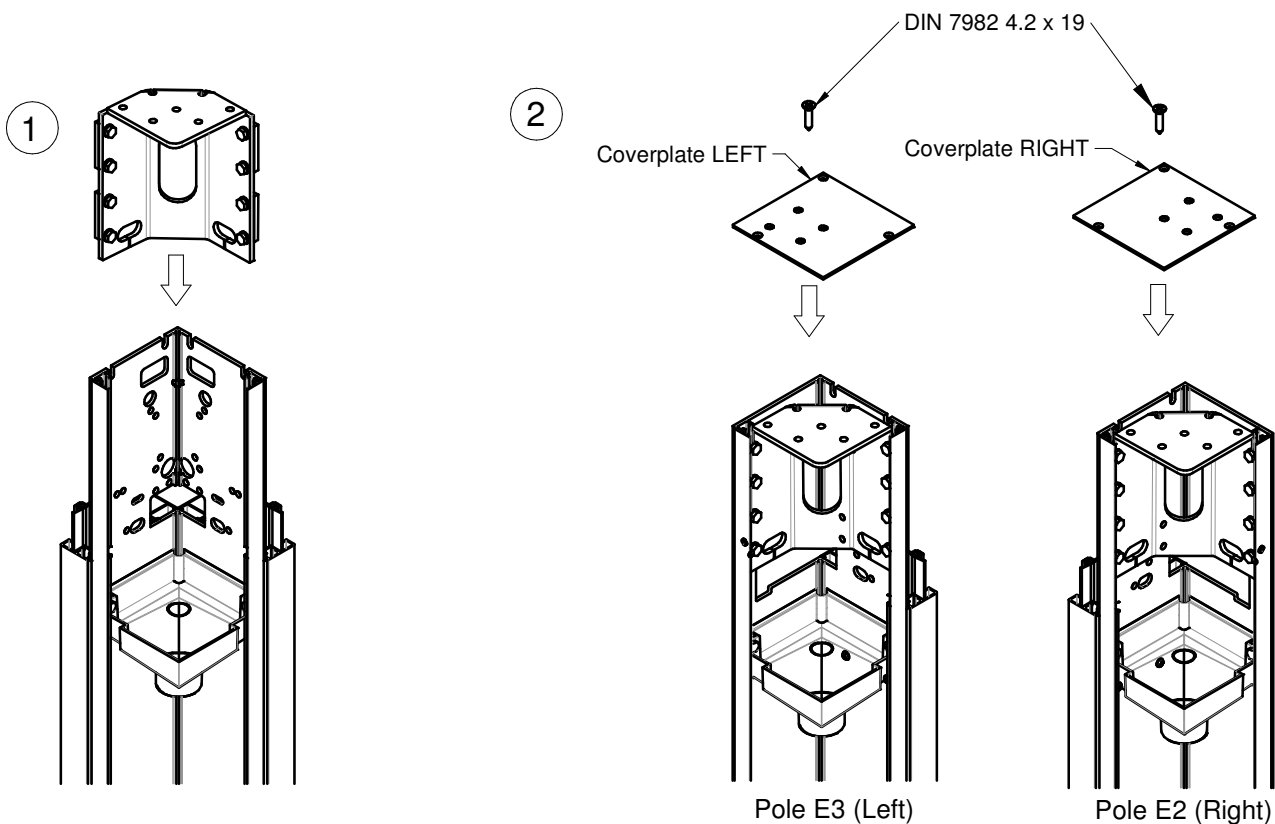

#### 2. Fitting the hinge for the arm profile

- › Fix the hinge on the coverplate of the vertical pole as shown on the drawing below.

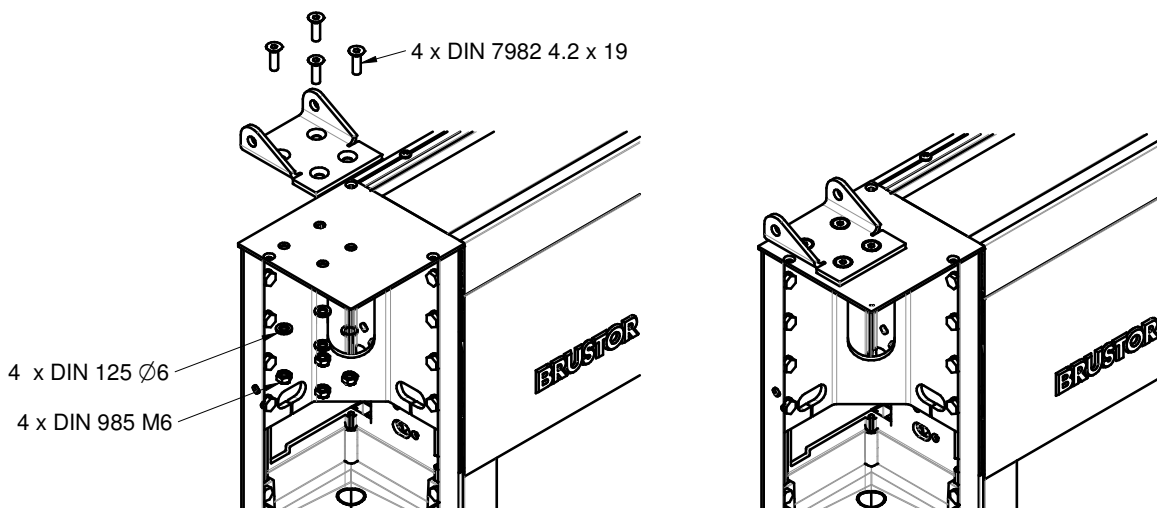

> If it is a construction with three arms and the middle arm goes to a door pole on W1, slide the connecting piece in the door pole, screw the coverplate on top and fasten the hinge on the connecting piece through the coverplate.

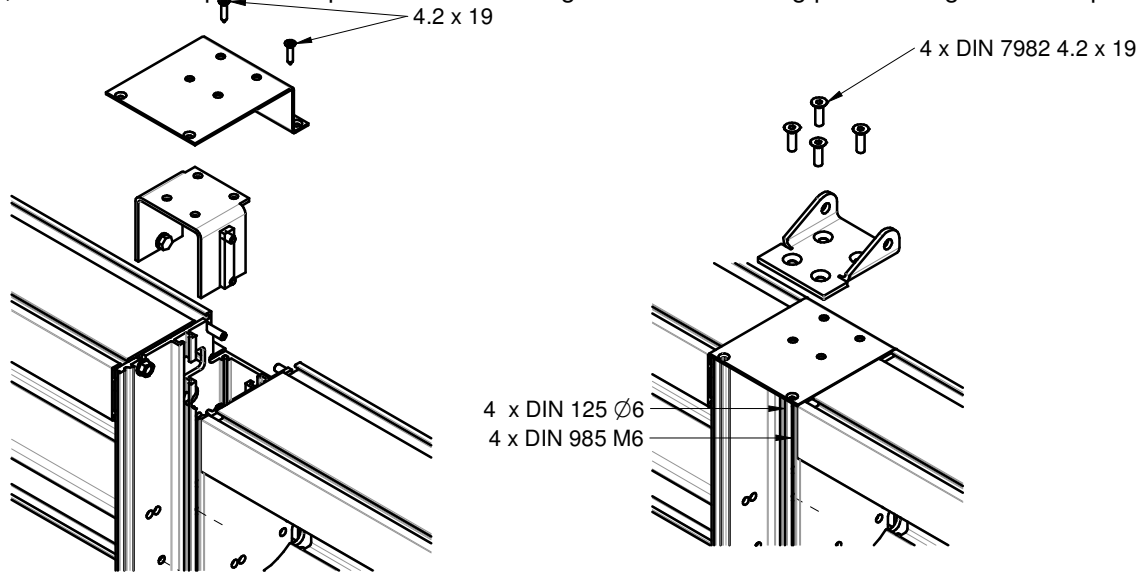

> With a construction with three arms and the middle arm is on beam W1, fit the hinge perfectly in the middle between the two other hinges.

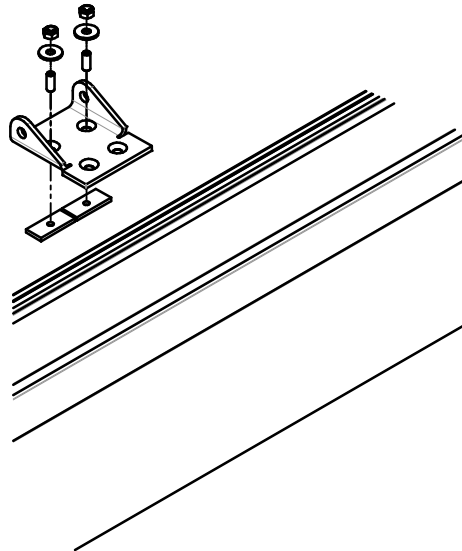

### 5.b FITTING THE WALL BRACKETS

- > Fix the wall bracket on the arm (1). Make sure that the bolt is in the back of the slot (2). Do not yet tighten the nuts.
- > Place the arms at the front on the just assembled hinge piece, do not yet tighten the nuts. (3)
- > Position the arm and determine the exact position of the wall bracket on the wall. Make sure that the wall bracket is centred on the arm and stays within the width of the arm. (4)
- > Mark the position of the wall bracket.

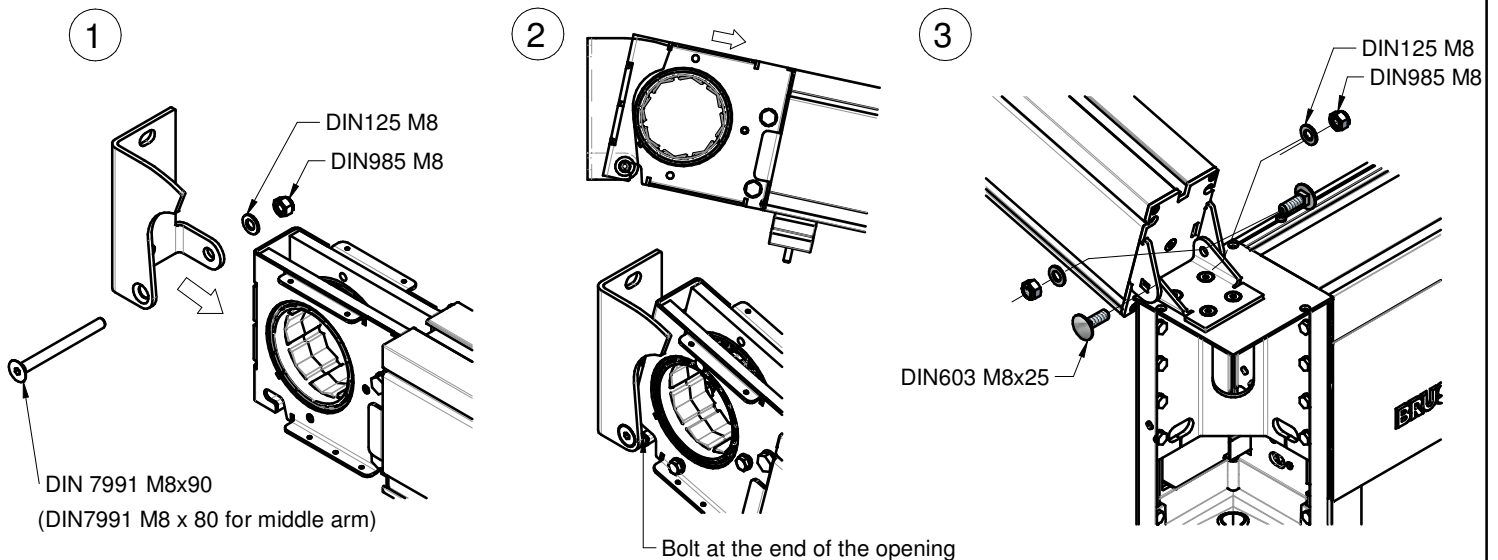

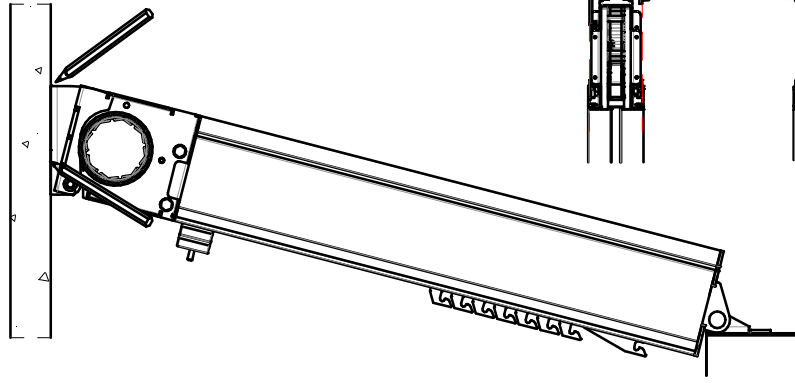
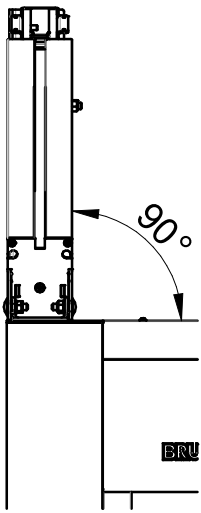

4

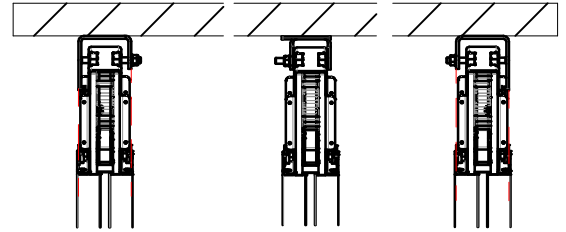

- › Disassemble the wall bracket and the arm of the hinge and fasten the wall bracket in the correct position.
- › The recommended fixing material is a M10 threaded rod with chemical anchor or M10 anchor bolts with nut..

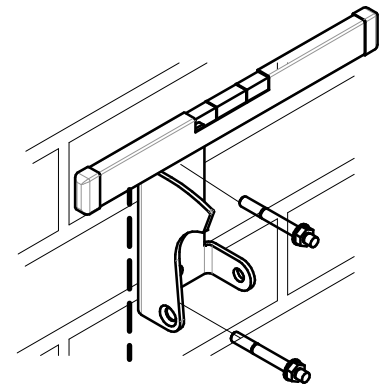
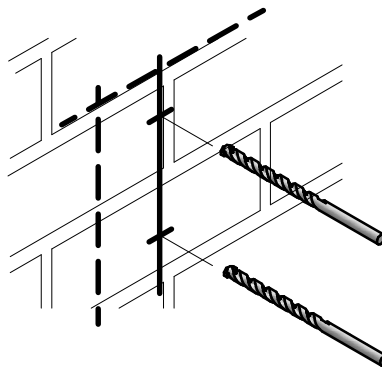
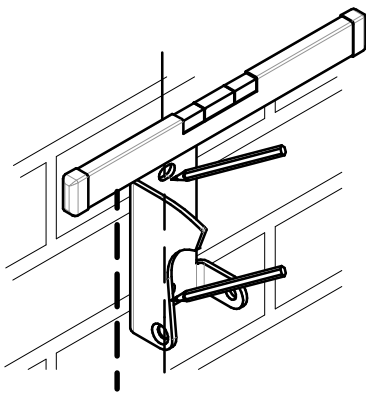

### 5.c ASSEMBLY ARMS & ROLLERTUBE

- › Fix the arm on the wall bracket, making sure that the bolt is at the back of the slot. (1)
- › Place the arms at the front on the hinge piece and tighten the nuts. (2)

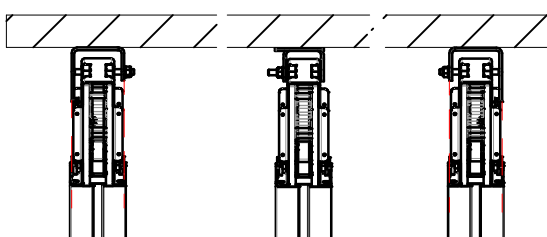
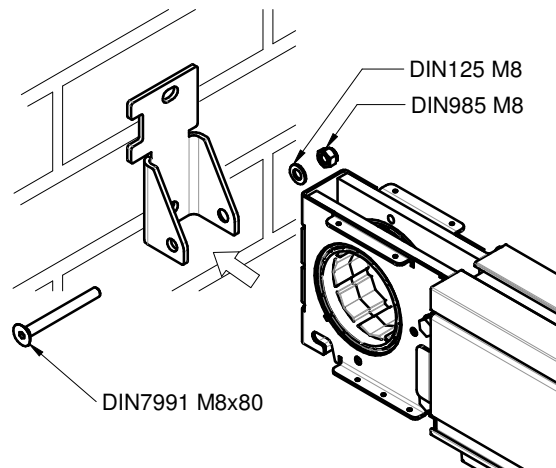
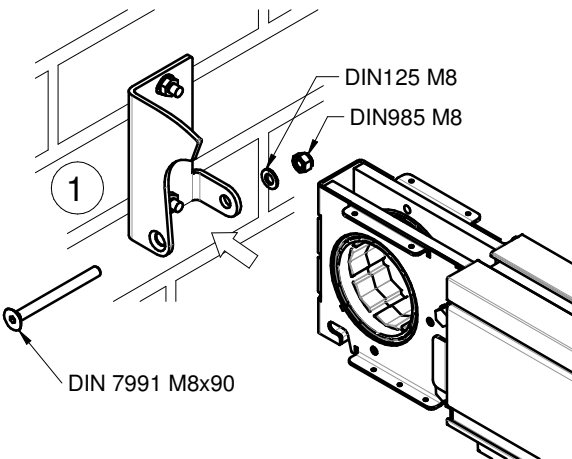

2

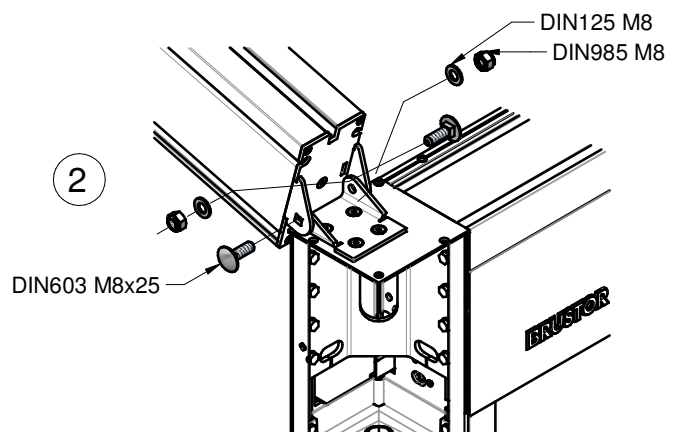

- ! > Check the perpendicularity with the measurements below ( $L1 \pm 1/8''$  !).
- > Also check the diagonals on the top side.
- > If necessary further adjust the wall supports a little.

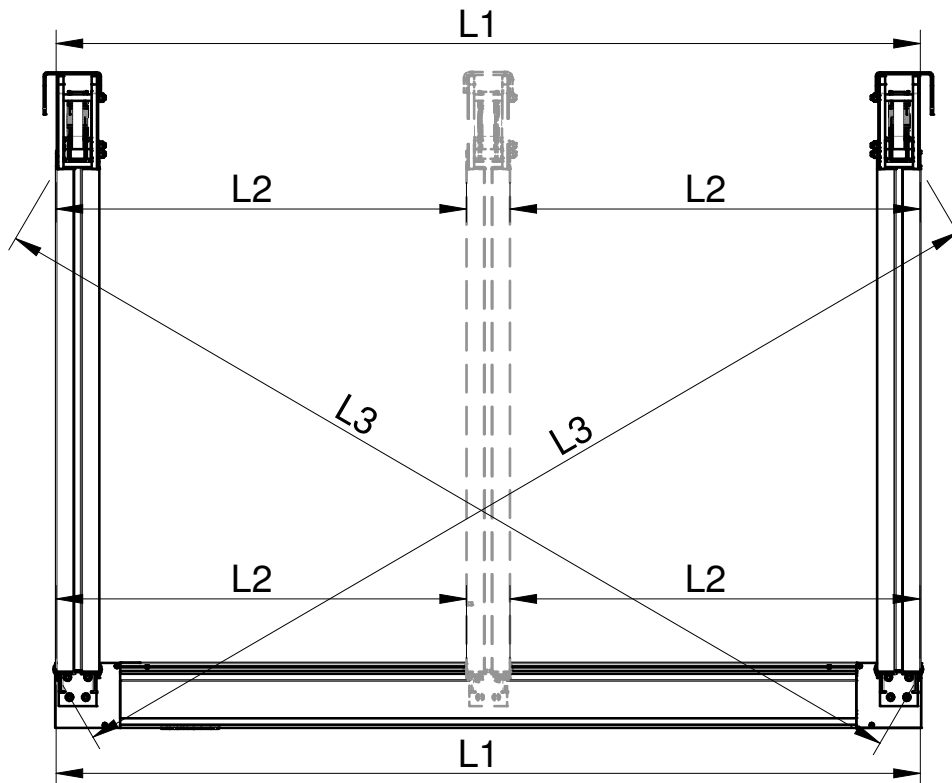

- > Check whether the first carriage of each arm is in the same position (measurement A).
- > If this is not the case, turn the belt of the arm until they are in the same position.

#### 1. FREE STANDING CONSTRUCTION (ROLLERTUBE IN 1 PART)

- > Slide the rollertube in the arms.

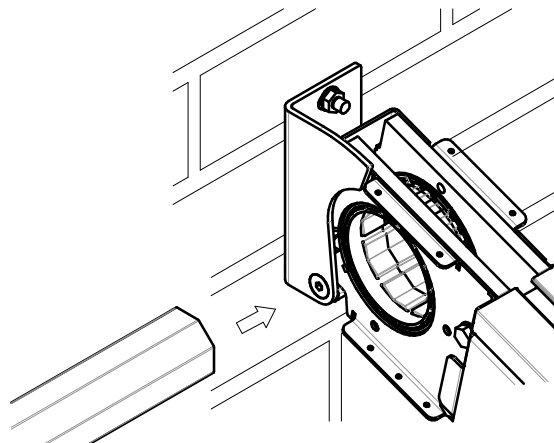
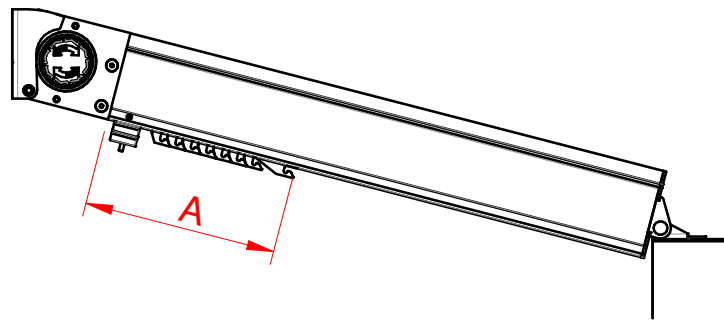

## 2. ENCLOSED CONSTRUCTION (ROLLERTUBE IN 2 OR 3 PARTS)

### Construction with 2 arms:

- › Place the left-hand part of the rollertube (1)
- › Slide the coupling profile in this left-hand part of the rollertube (2)
- › Place the right-hand part of the rollertube (3)
- › Slide the coupling profile from the left-hand part in to the right-hand part of the rollertube
- › Fix the coupling profile on both parts of the rollertube with 4 bolts (DIN931 M6 x 75)

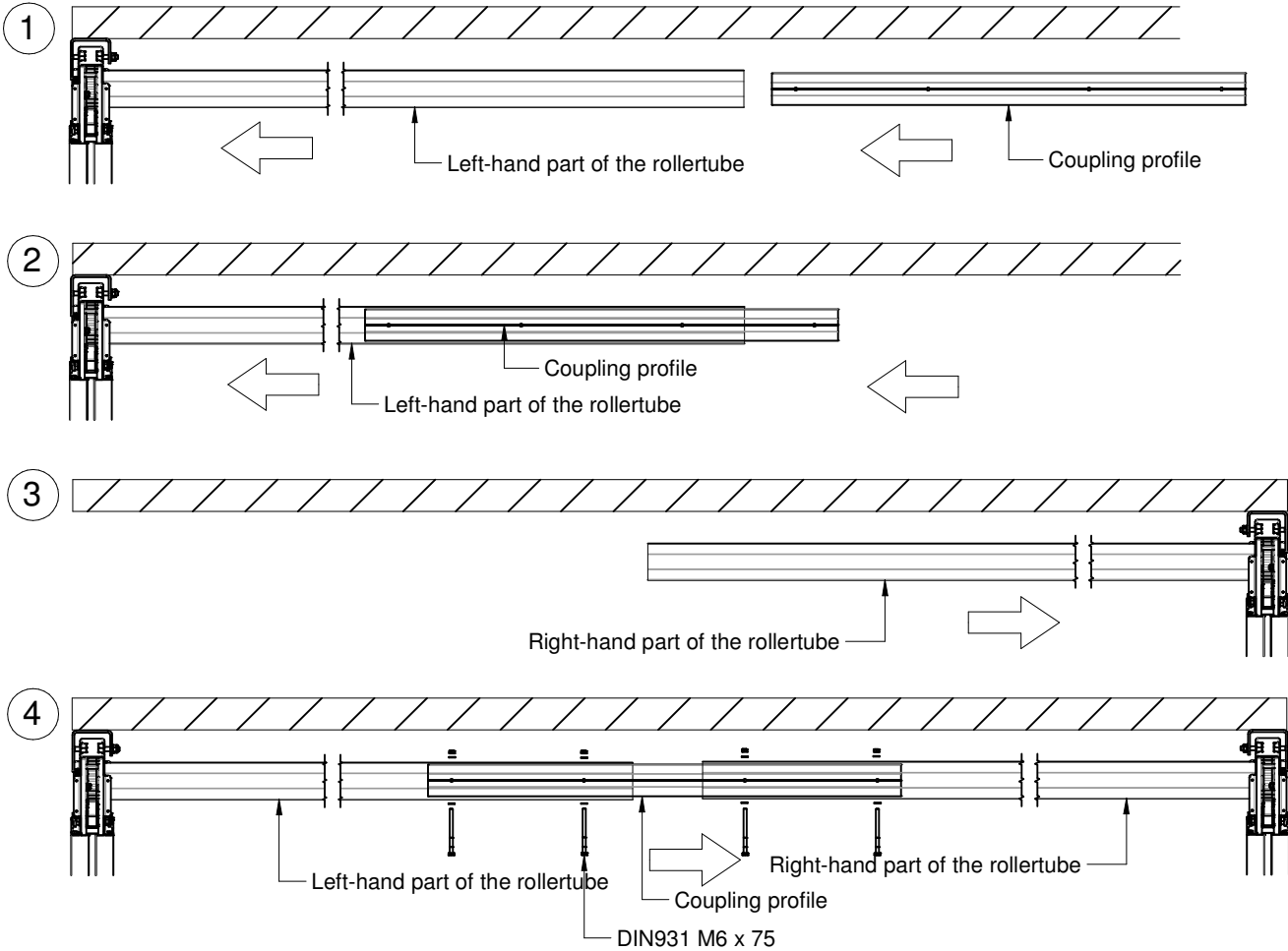

### Construction with 3 arms:

- › Fit the coupling profile in the middle arm (1)
- › Place the left-hand part of the rollertube (2)
- › Slide the coupling profile in this left-hand part (3)
- › Place the right-hand part of the rollertube (4)
- › Slide the coupling module from the left-hand and middle part in the right-hand part of the rollertube (5)
- › Fix the coupling profile to the three parts of the rollertube with 4 bolts (DIN931 M8 x 75)

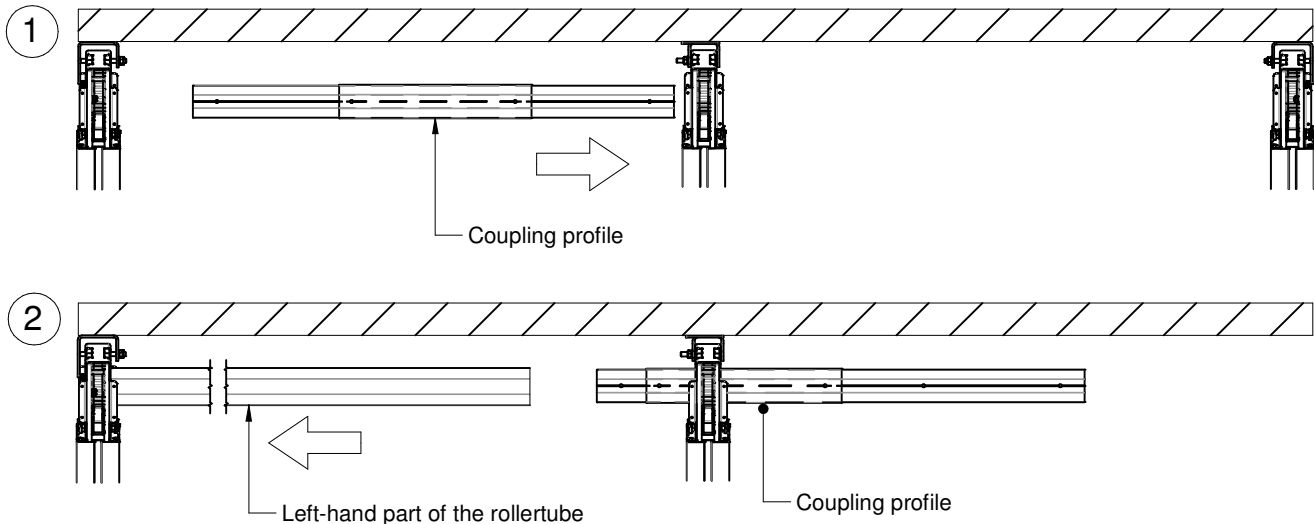

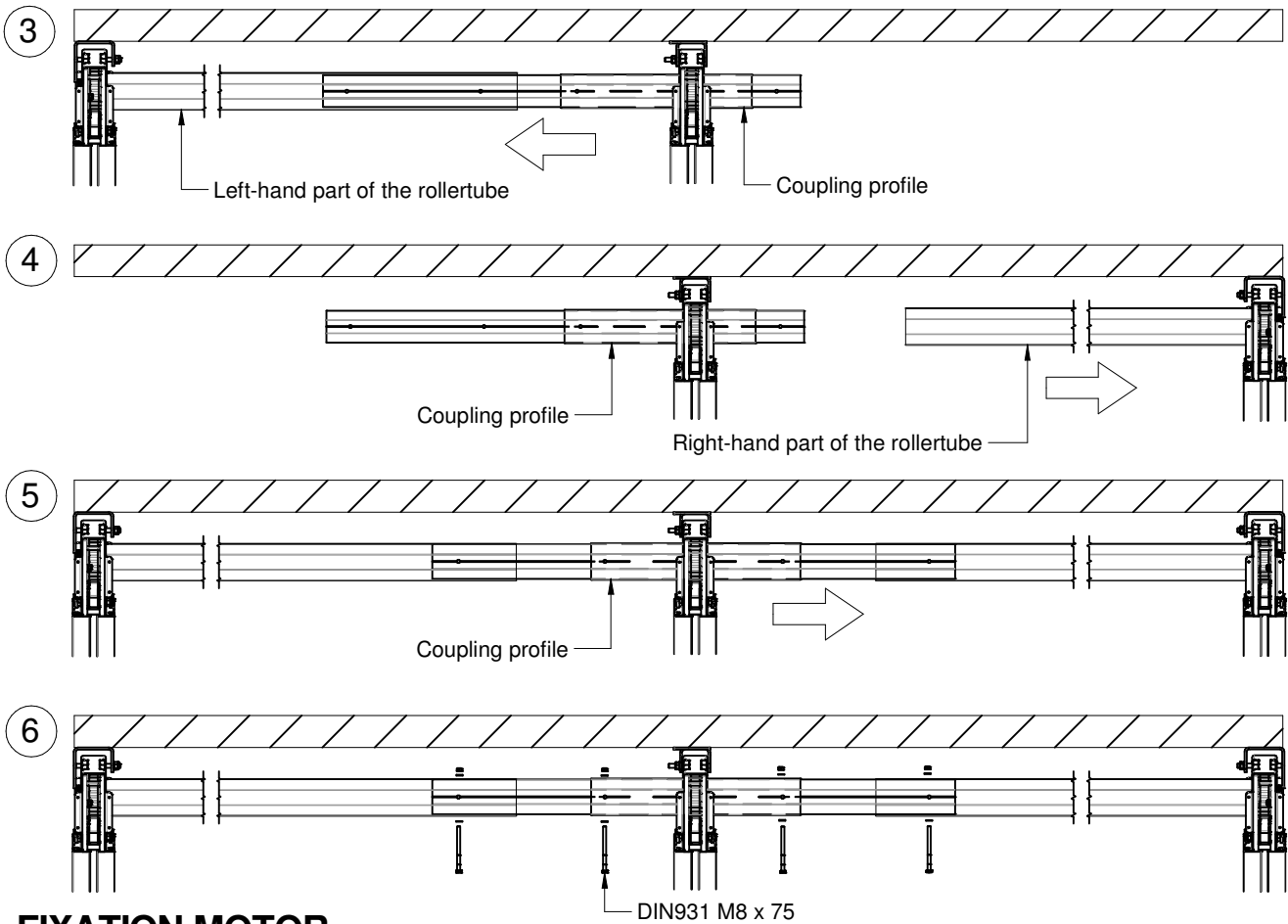

## 6. FIXATION MOTOR

- › Place the motor plate over the end of the motor and tighten with 3 bolts and (DIN933 M6 x 25) and 2 nuts.
- › Do not fit a nut on the bolt nearest to the arm profile!
- › Lock the motor head with the circlips.
- › Also fit a motor plate on the bearing side. This stops the rollertube from wandering. Do not fit a nut on the bolt nearest to the arm profile.

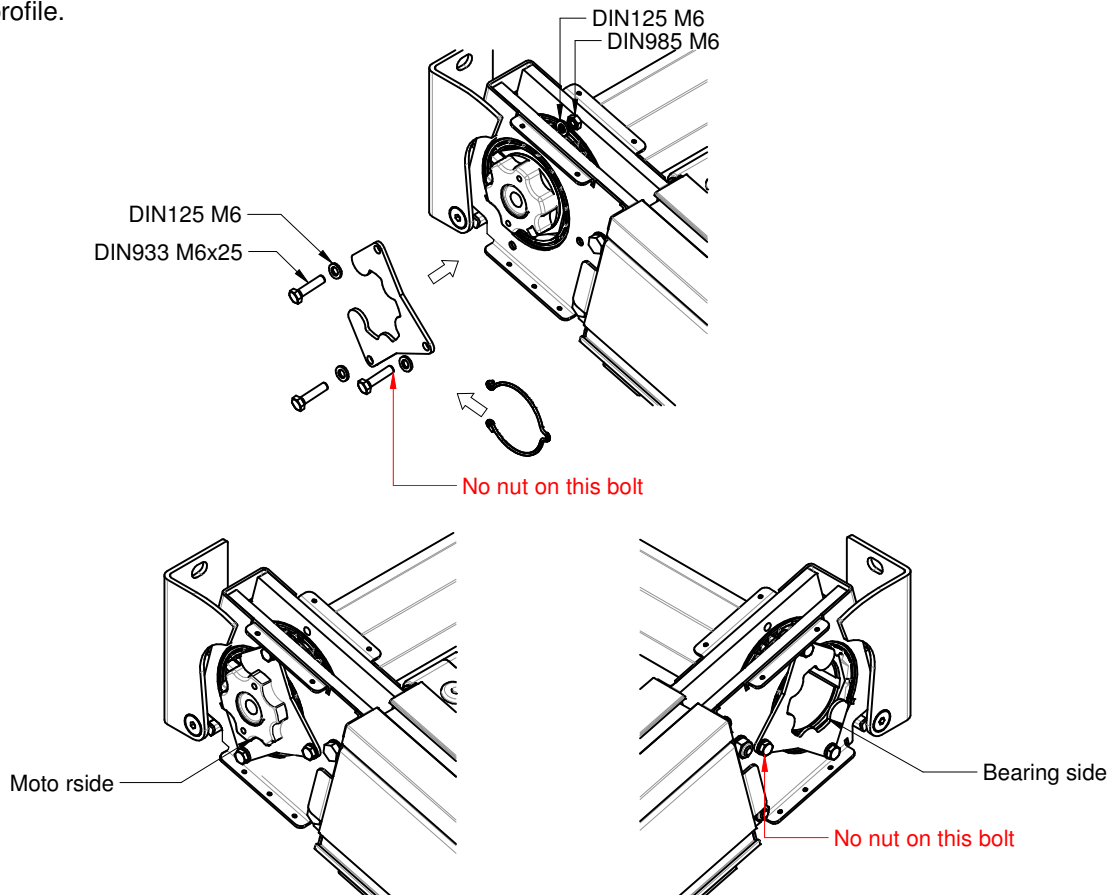

## 7. ASSEMBLY FOLDING FABRIC

- › Hook the first flowprofile in the first carriage, the second flowprofile in the second carriage,...
- › Allow the last profile and the fabric fixation profile to hang loose.
- › Connect the folding fabric motor and allow the fabric to slide up.

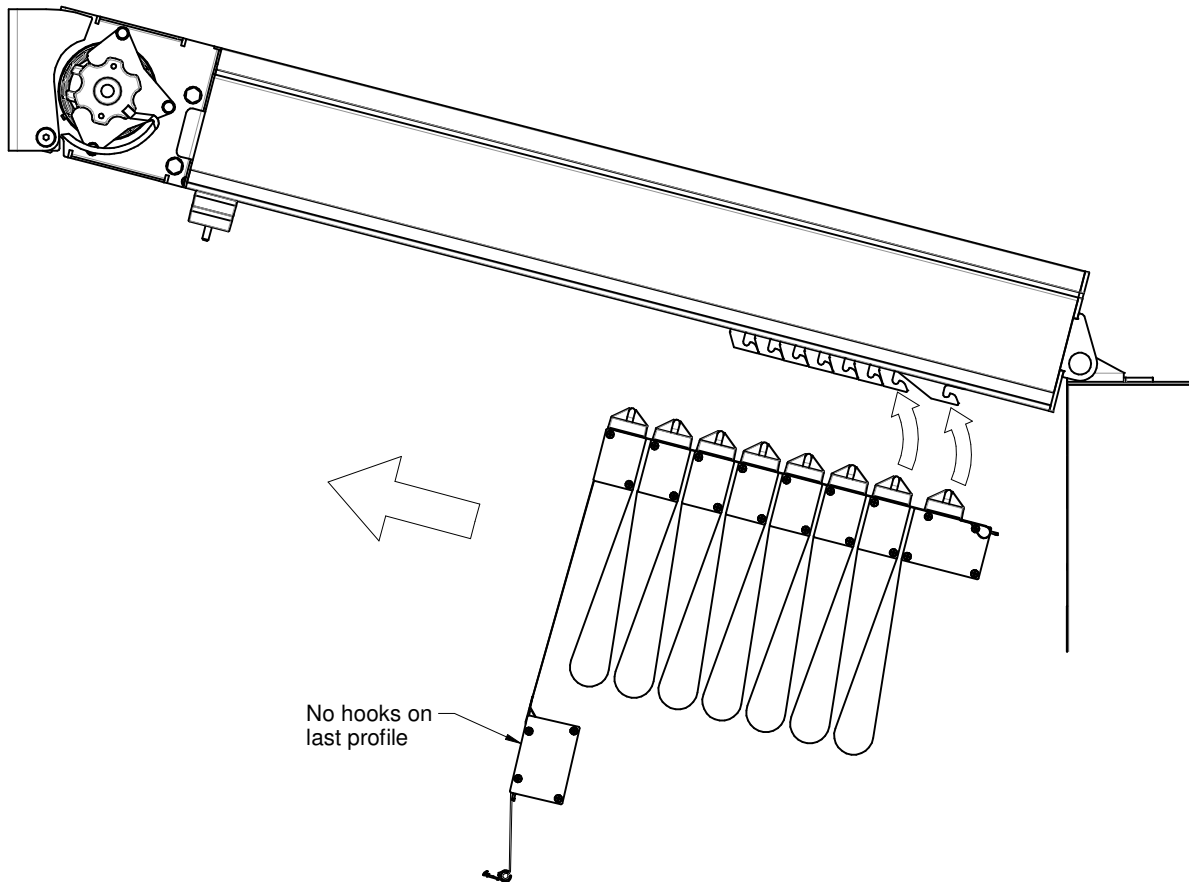

- › Slide the last profile over the bolts fixed to the guides. (1)
- › Make sure that the synthetic blocks with the bolt can still slide in the profile.
- › Fix with a DIN985 M6 nut approximately 3/8" from the end of the arm profile. (2)
- › Clip locking clips on each hook.(3) (Centre the end of the clips perfectly between the legs of the carriage).

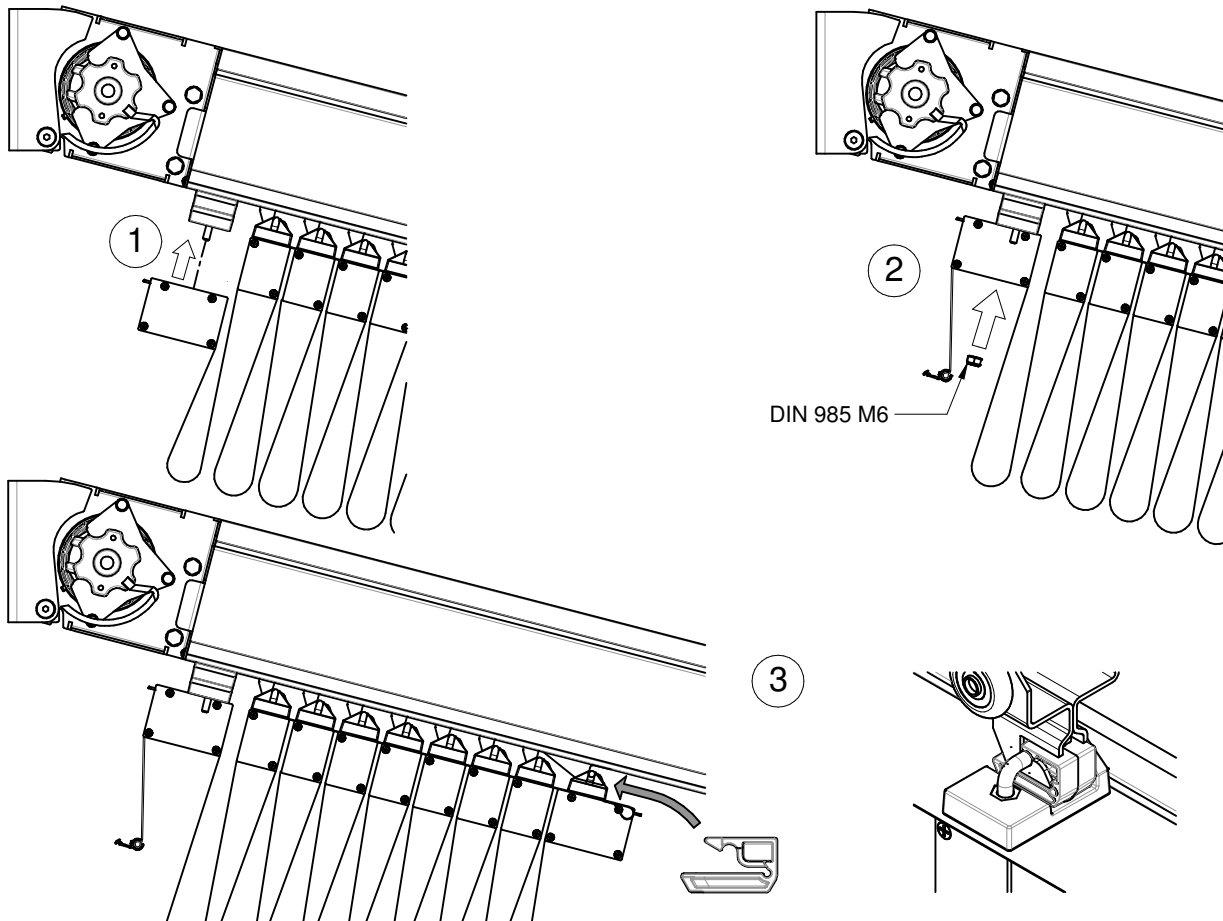

## 8. PLACING THE RAINGUTTERS

- › Drainage must be provided in the poles at the front (E2 et E3).
- › Tilt the rain gutter in the mainhousing W1 and slide the extension of the raingutter over it.
- › Fit the end cover of the raingutter and tighten a self-tapping screw DIN7504 Ø4,2x13.
- › Insert a screw DIN916 M5x16 in the end piece to fix the raingutter.

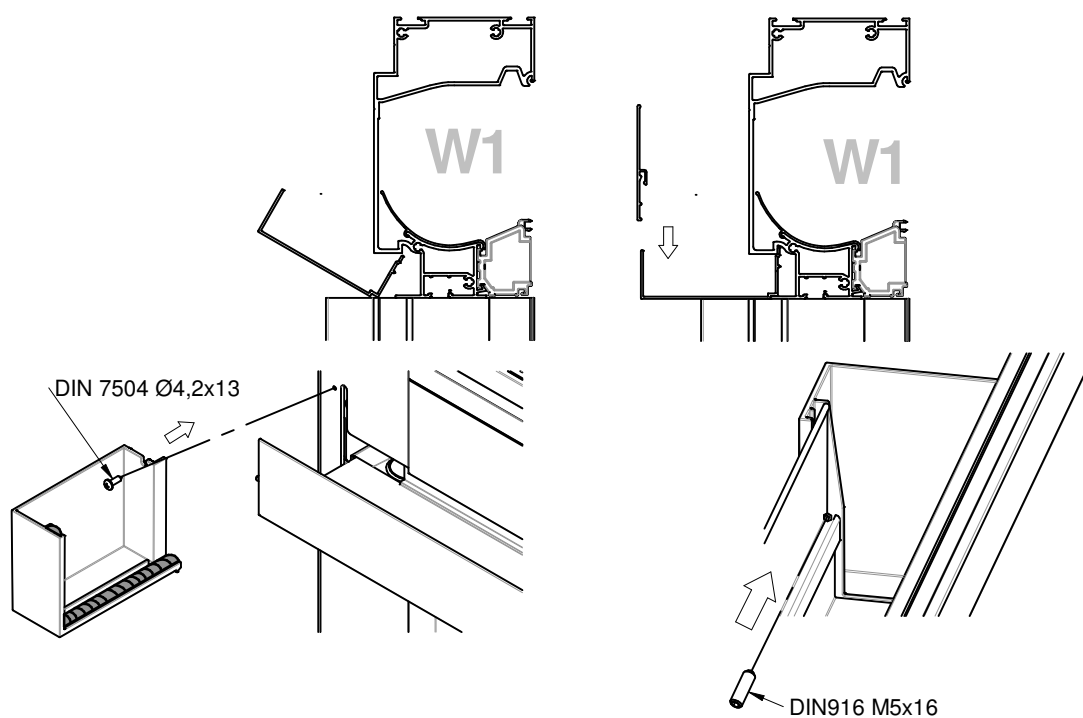

## 9. SCREENS

### 9.a ROLLERTUBES

- › If 3 screens are provided, always start with the one furthest from the electrical connection.  
(number 1 in the figure below)

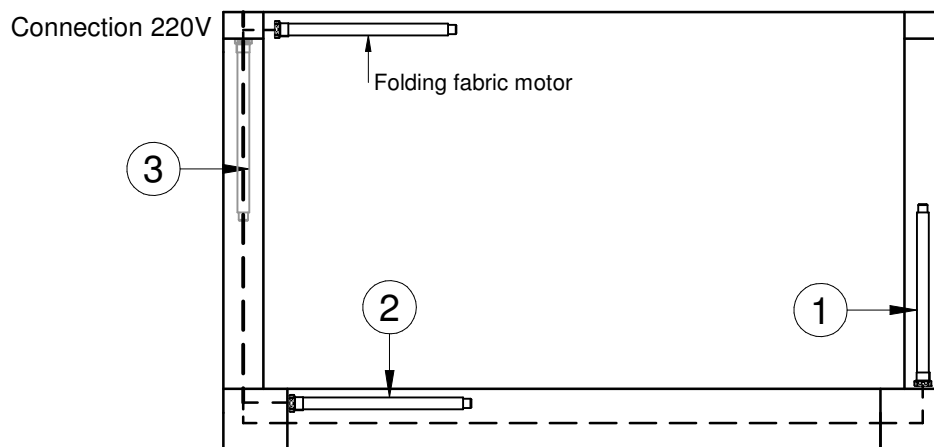



› The roller tube supports can be assembled in two ways depending on the type of fabric. See below

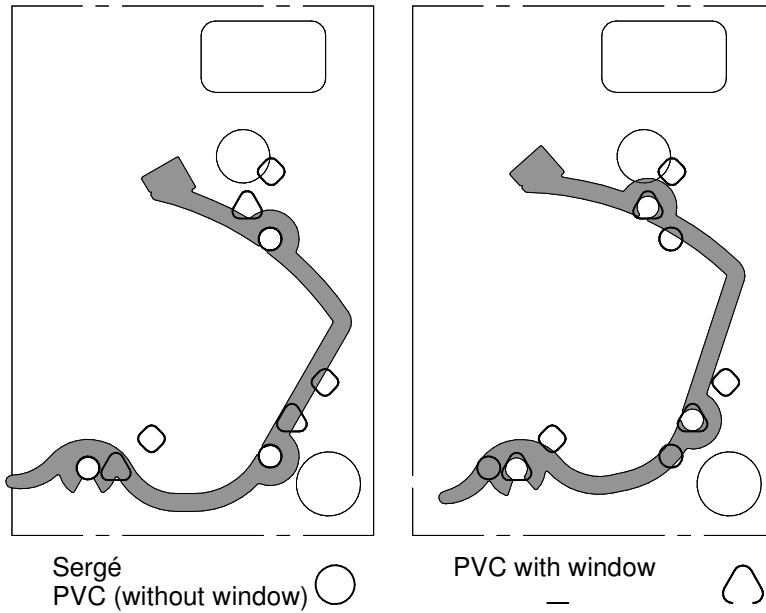

### VERTICAL POLES

- › Fix the rollertube supports to the vertical poles (3 x M6x25) (1).
- › Bring the screen in according to the drawing below (2) and block it on both sides (M4x20) (3).

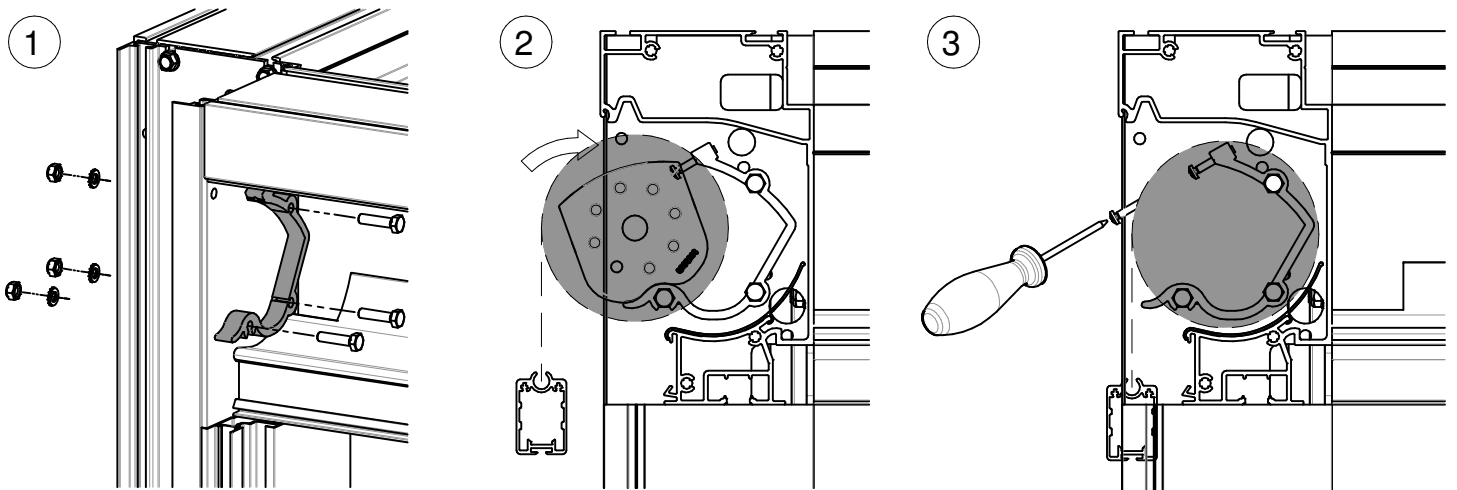

### DOOR POLES

- › Fix the rollertube supports to the door poles as shown below
- › Do not use a ring on the side where a rollertube support is mounted.
- › Two rollertube supports can be mounted per pole.
- › Bring the screen in according to the drawing below (2) and block it on both sides (M4x20) (3).
- › With poles E1 and E4 (door posts on the wall), fix the rollertube support with bolts (2 x M6x25).

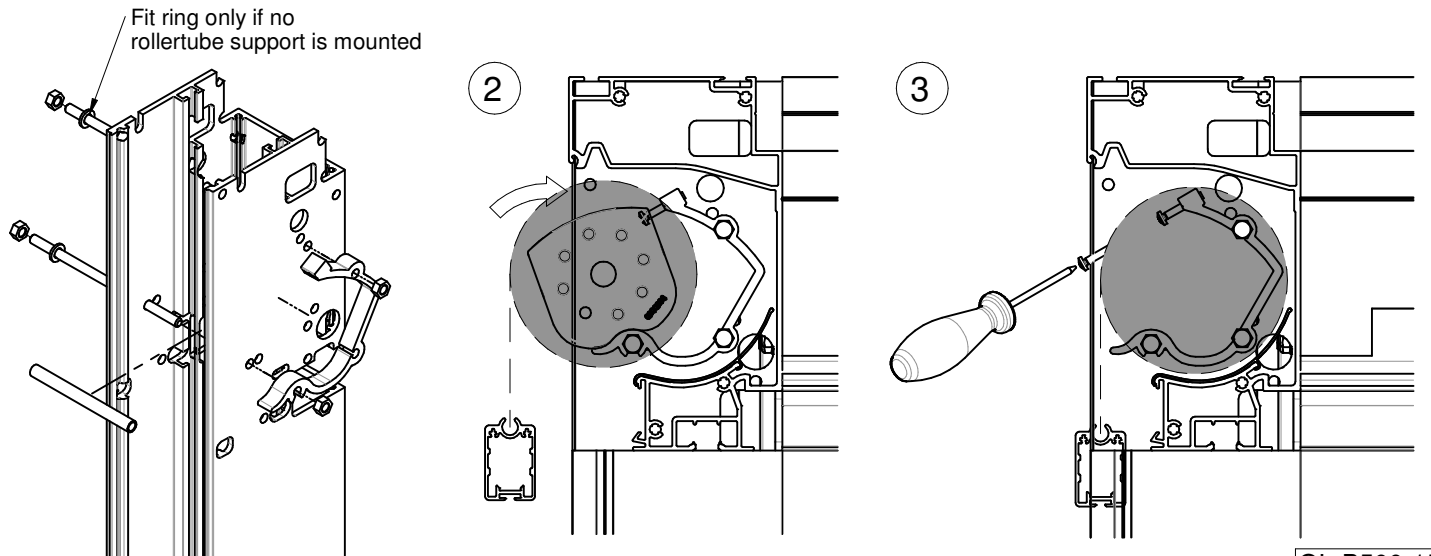

## 9.b MOTOR CABLE

- › Lay the motor cables as shown in the drawings below.
- › Steps 2 and 3 only apply for the furthest screens.
- › If applicable, conceal these cables under the PVC fabric support as well.
- › In some cases it will be necessary to conceal the cable behind the screen during mounting of the screens.

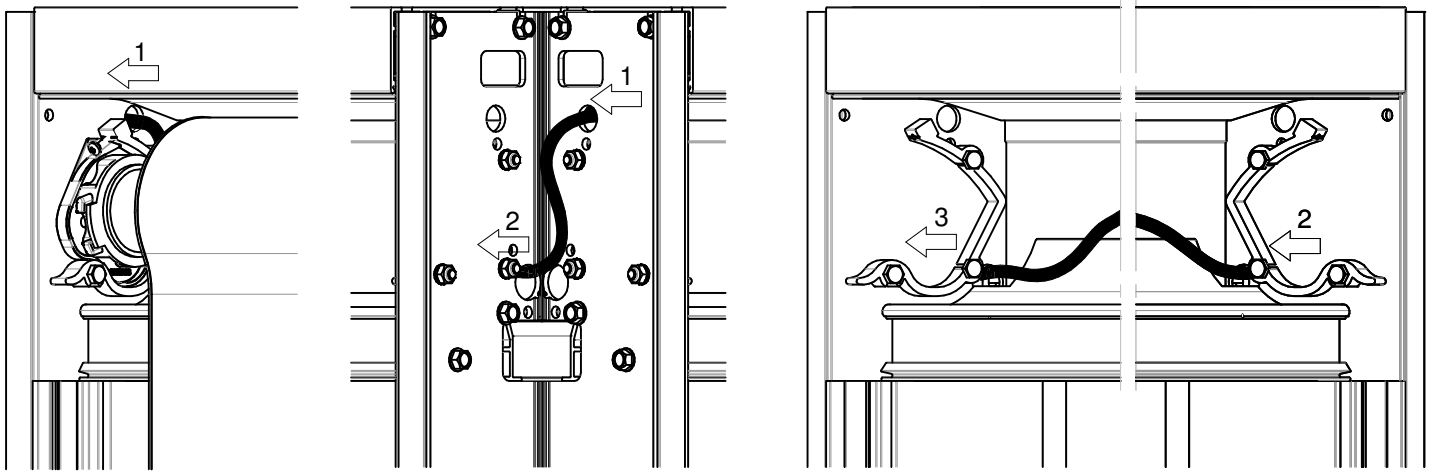

- › After the assembly of all motors the following situation should be obtained at the electrical connection in the door pole on the wall. (1)
- › If there are no side screens, bring the screen cable and/or LED cable through the arm upwards and connect it there. (2)
- › For this, drill a hole in the aluminium plate on the pole and seal with silicone. (2)
- › The connection is explained later.

① WITH SIDESCREEN

② WITHOUT SIDESCREEN

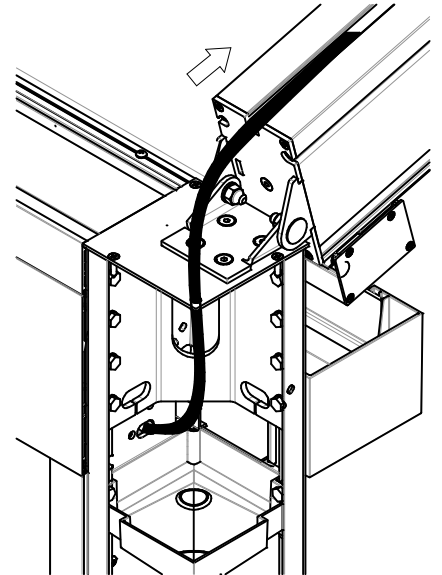
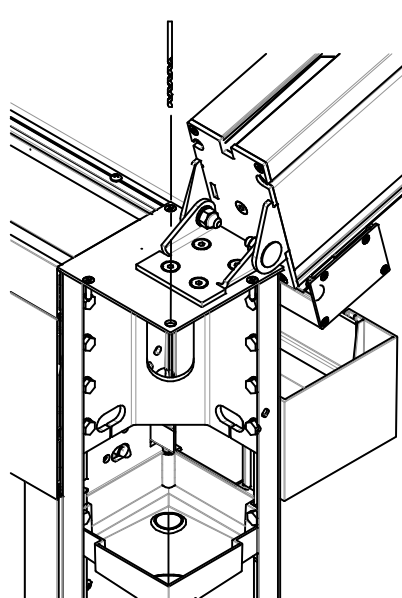
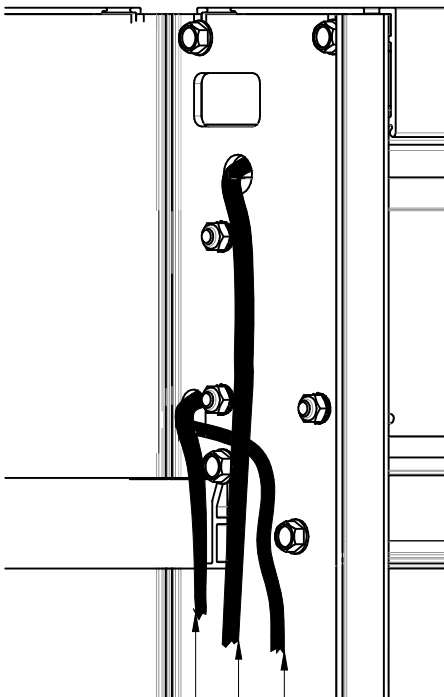

Cable screen motor (no. 2 in figure 9a)  
 Cable screen motor (no. 1 in figure 9a)  
 Cable screen motor (no. 3 in figure 9a)

## 10. SCREEN GUIDES

### 10.a LEADRAIL

- › Place the leadrail temporarily on the housing to ease assembly of the guide leadrails.
- › Place the guide leadrails in the groove under the screen.
- › Press the guide leadrails firmly down when screwing tight.

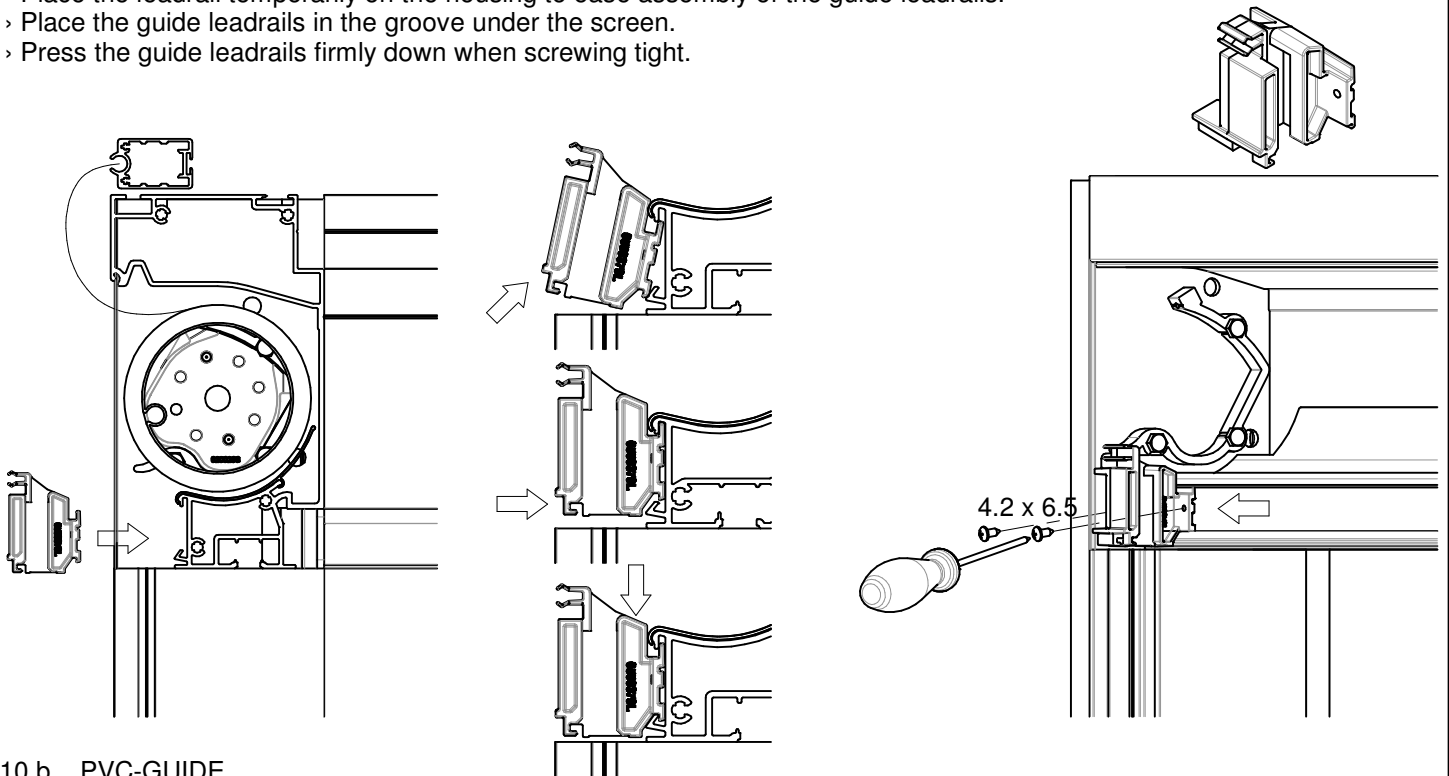

### 10.b PVC-GUIDE

- › Slide the leadrail left and right in the guide leadrail and allow the fabric to lower approximately 30cm .
- › Slide the PVC guide over the zipper fastened left and right on the fabric. (1)
- › Hook the siderail cover behind the PVC guide. (2)
- › Click the profile shut at the bottom and slide it downwards over the pins (3) fixed on the bottom of the guide.
- › Theb click the rest of the profile shut.

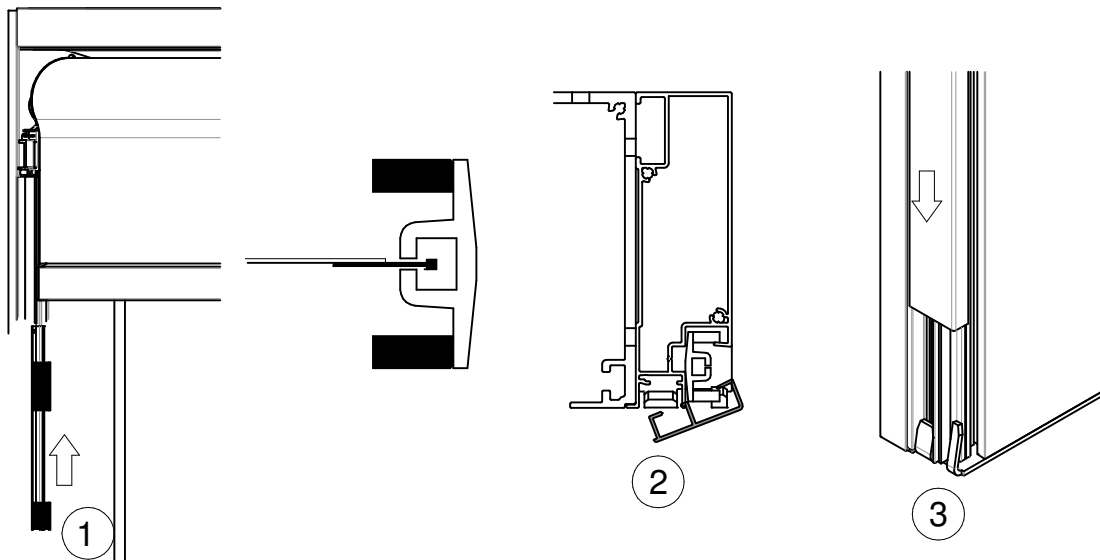

- › Take care when opening the guide.
- › Start opening the guide with the upper clips and work clip by clip downwards.
- › Always pull on the cover profile as near as possible to the clips or the cover profile may distort.

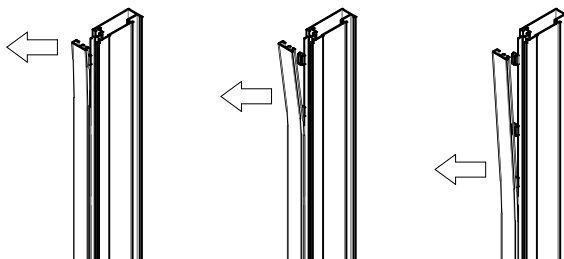

## 11. ADJUSTING THE ENDPOINTS

- › With a number of screens and folding fabric motor:
- › Connect one of the screens to the main voltage (220V).
- › Fully program this motor up to and including the allocation of the transmitter.
- › Cut of the power to the motor!
- › Now do the same with the other motors, connect them one by one and each time cut off the power.
- › When all motors have been programmed, connect them all to the main voltage again. (220V).

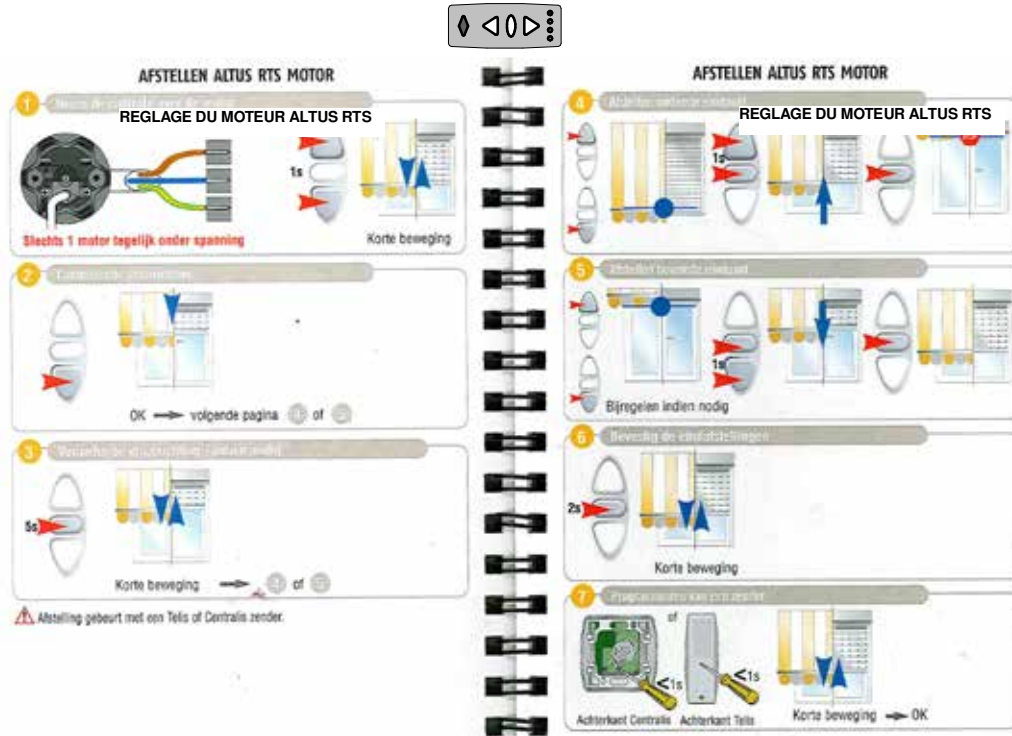

- › Set the folding fabric so the first flowprofile passes over the gutter on the W1 side(1)
- › Sliding the last flowprofile backwards will put more tension on the fabric. (2)
- › Sliding the last fabric profile forwards allow the leadrail to pass further over the gutter.(2)

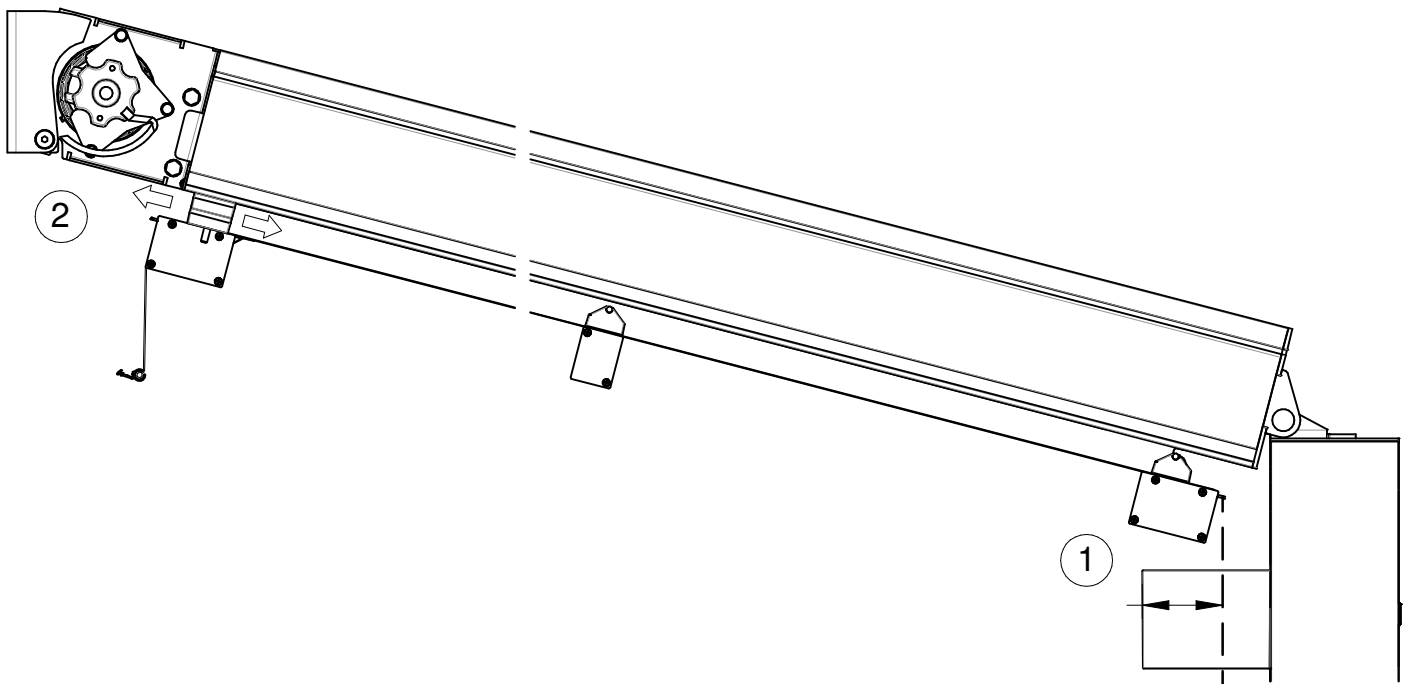

## 12. CONNECTIONS DIAGRAM

### 1. WITH SIDE SCREENS

- › The electrical control for the screens and/or LED strips in the frame is in door pole E1 or E4.
- The electrical control for the LED strips in the flowprofiles is on the arm on the side of the motor.

### 2. WITHOUT SIDE SCREENS

- › The electrical control for the screen on W1 and/or LED strips is on the arm on the side of the motor.

*The manual of each device is in the waterproof box of the electrical control.*

## 13. FINISHING

### 13.a COVER MAINHOUSING

- › Replace the M6x12 bolt from the corner reinforcement with the M6x25 bolt from the lock cover mainhousing. (1)
- › Hook the cover in the mainhousing and click shut left and right.
- › Make sure that the guide leadrails are nicely in place when closing the cover.
- › Block the cover mainhousing by tightening the bolt (M6 x 25) from the corner reinforcement.

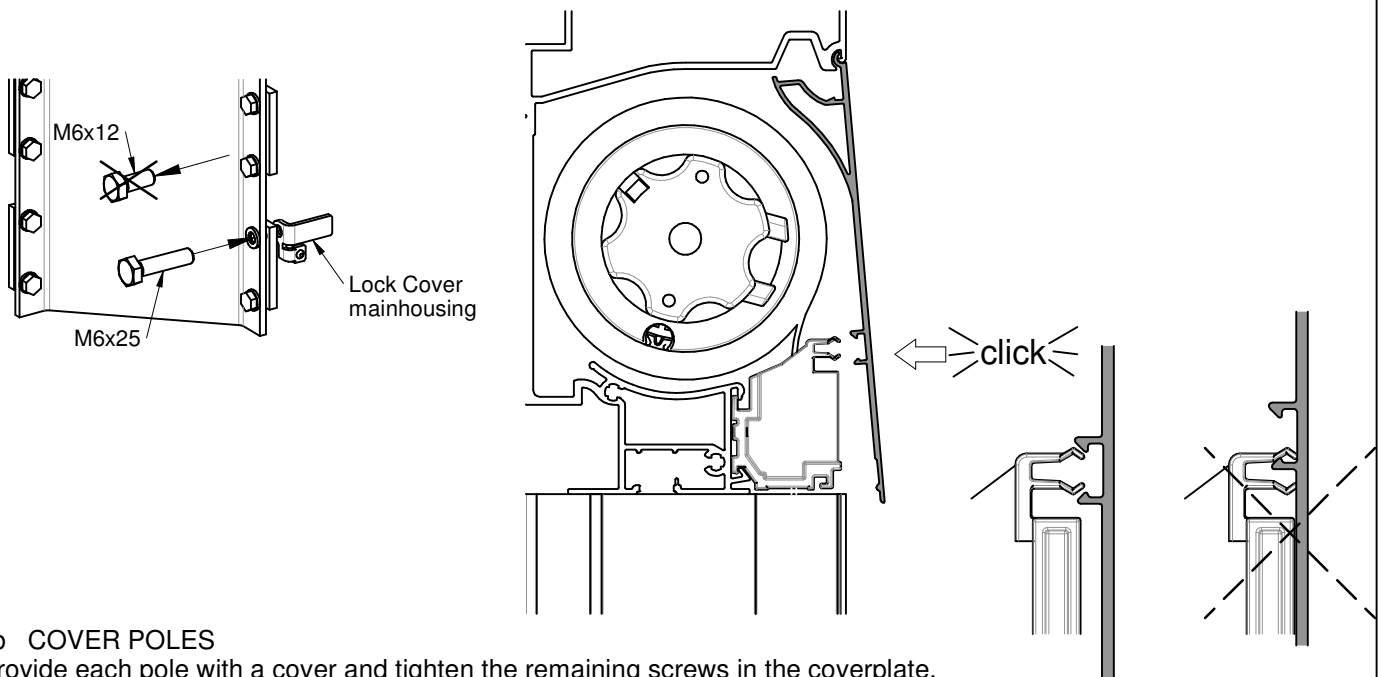

### 13.b COVER POLES

- › Provide each pole with a cover and tighten the remaining screws in the coverplate.
- › The covers can be mounted in two ways.

#### SINGLE

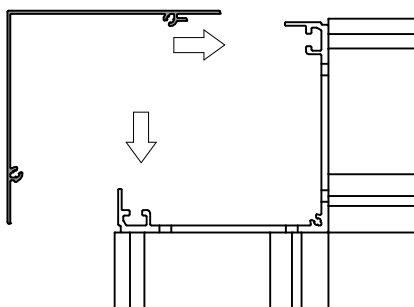

#### DOOR PROFILE

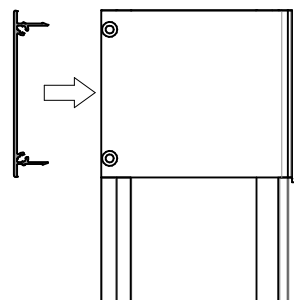

1x DIN7982 4.2x19

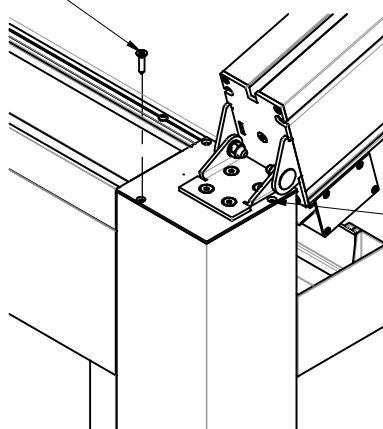

Don't screw here

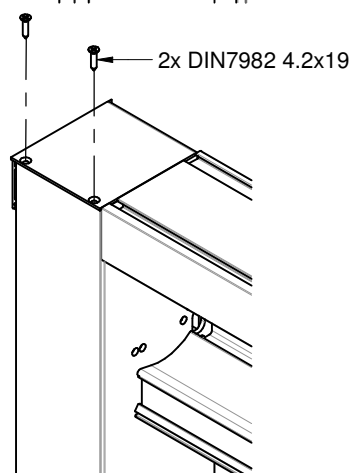

### 13.c COVERPLATE BOTTOM ARM

- › Place the cover plate on the bottom of the arm end and tighten with DIN965 M4 x 10.
- › Do this on the left arm and the right arm. The middle arm doesn't need a cover plate.

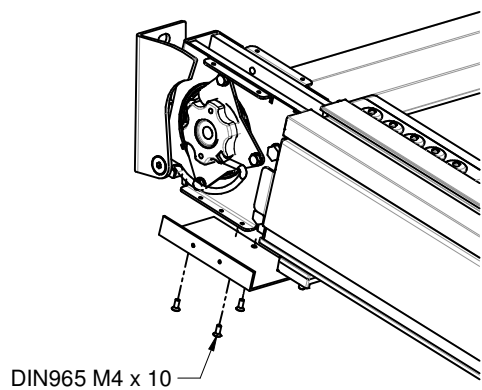

### 13.d FABRIC FIXATION PROFILE

- › Position the fabric fixation profile on the wall and mark where you are going to fix it.
- › Screw the fabric fixation profile tight to the wall every one and a half metres.
- › Push the rubber seal in the fabric fixation profile to cover the screws.

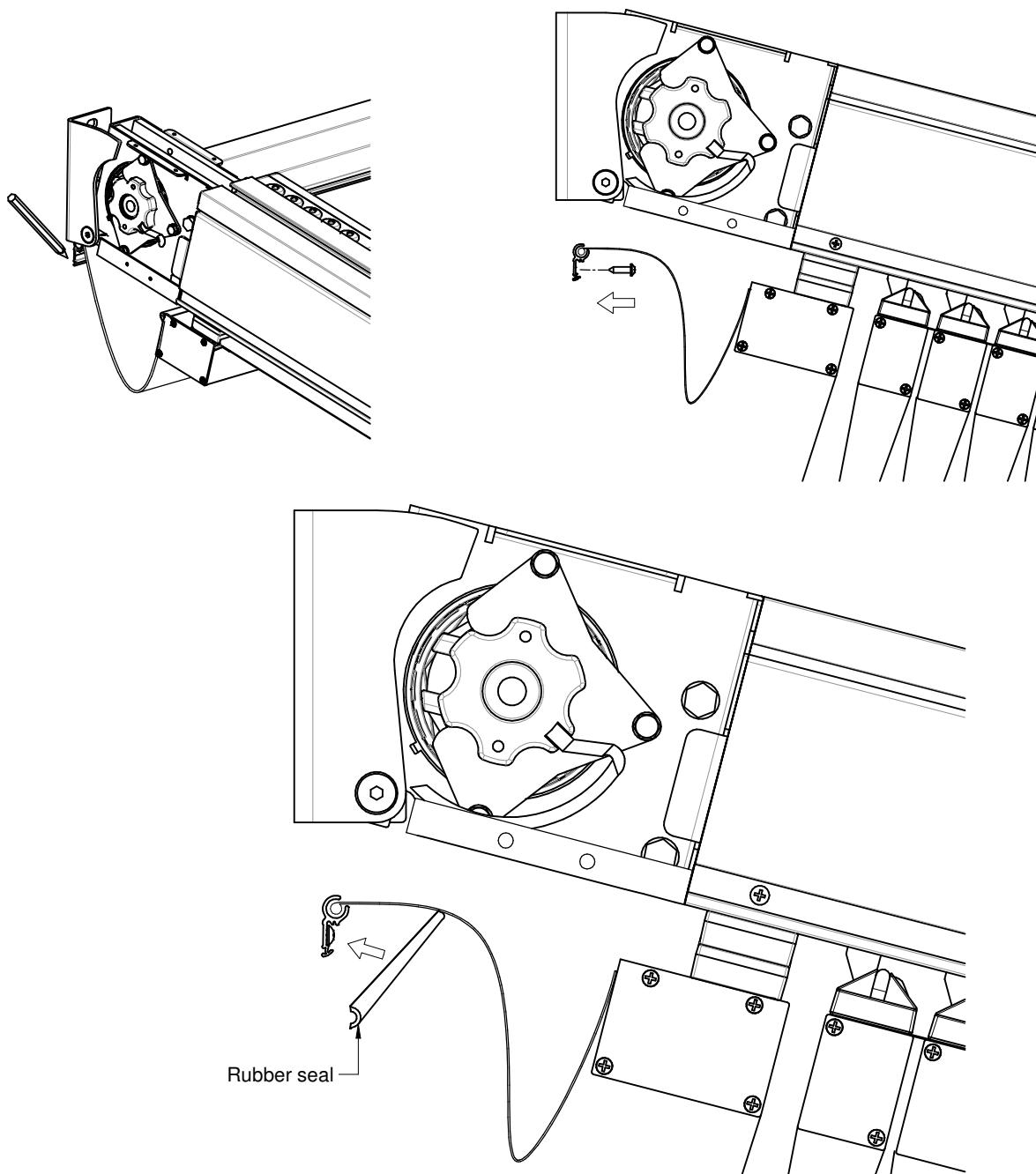

### 13.e FITTING SEALING RUBBERS

- › Press the sealing rubber in the slot in the inner side of the arm.
- › Do not put any rubbers on a middle arm.

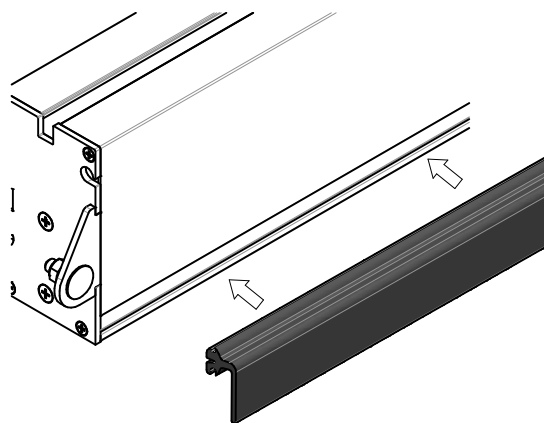

### 13.f TRIANGULAR SCREENING

- › Fit the shortest piece of tensioning profile on the post with self-tapping screws.
- › Fit the longest piece of tensioning profile on the wall with suitable fixing material.

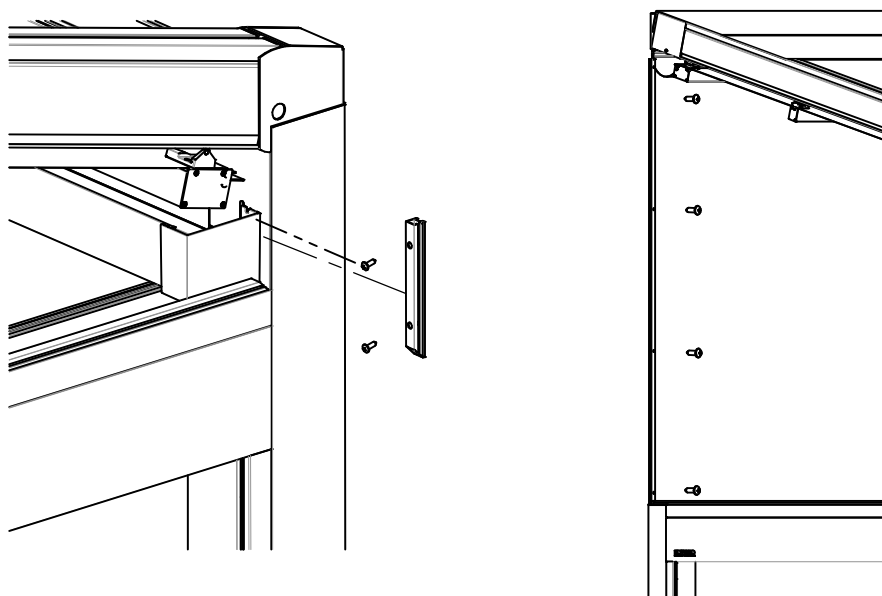

- › Slide the fabric in the slot on the outside of the arm and pull it up against the wall.
- › Pull the screen cord approximately 5/8" back to be able to pull the fabric to the wall.

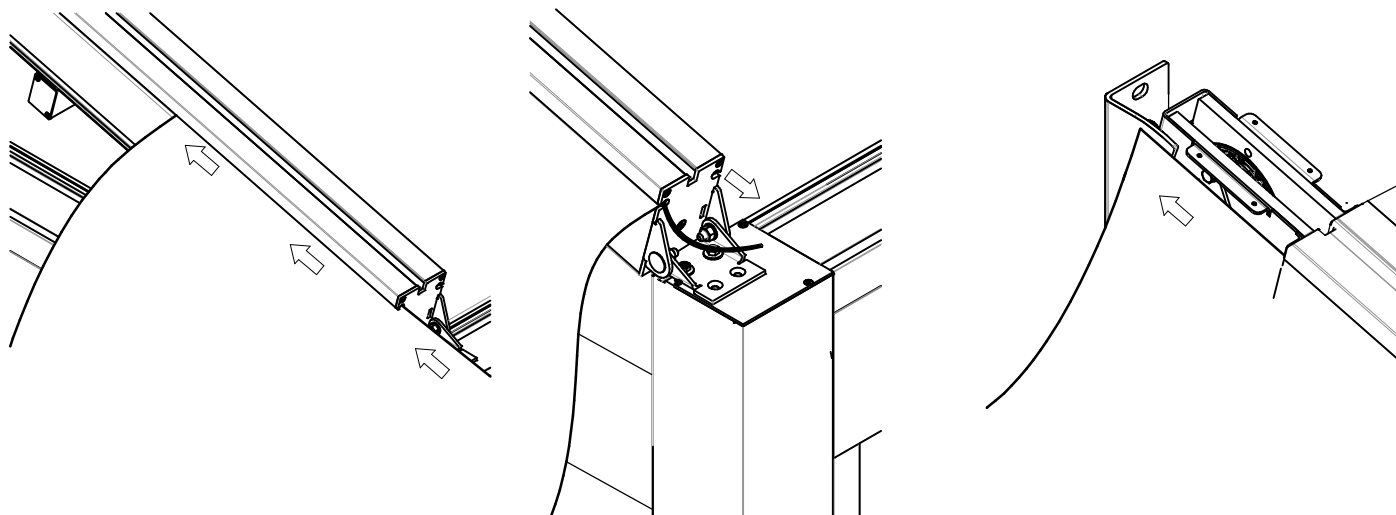

- > Cut the fabric around 4" too large so it overlaps all the tensioning profiles.
- > Push the synthetic profile in the aluminium tensioning profile with the fabric in between (start in a corner).
- > Do not tighten the fabric before you assemble the synthetic profile. The fabric is automatically tensioned when pushing in the synthetic profile.
- > Cut the fabric off along the synthetic profile.

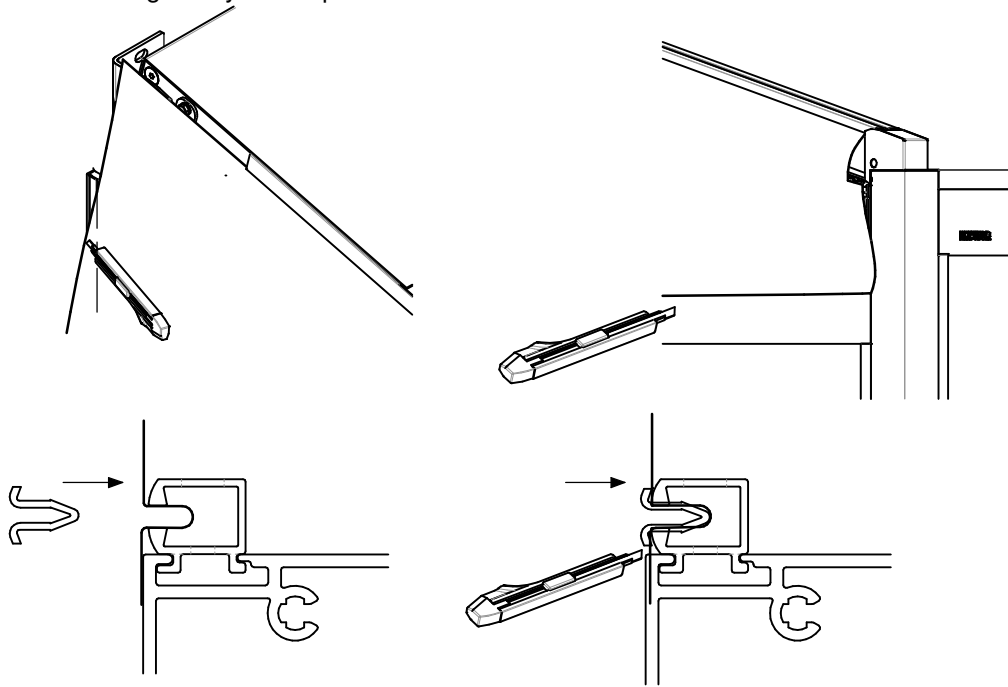

- > The corner of the side fabric can be stuck with a piece of double-sided tape on the motor head or the wall bracket so the fabric remains well stretched.

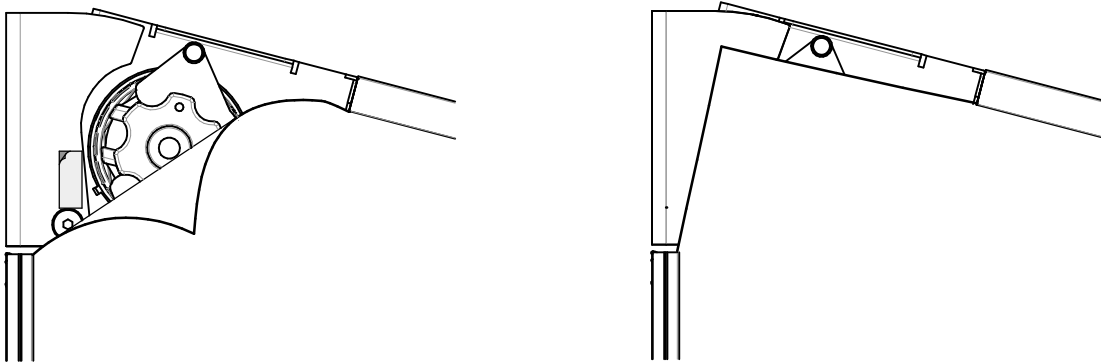

### 13.g SIDEPLATE ASSEMBLY

- > Fasten the side plate on the end of the arm with DIN965 M4 x 10 screws. (1)
- > Fasten the side plate on the already assembled cover plate on the bottom of the arm. In the case of side fabric, the side fabric must be punctured in this place.

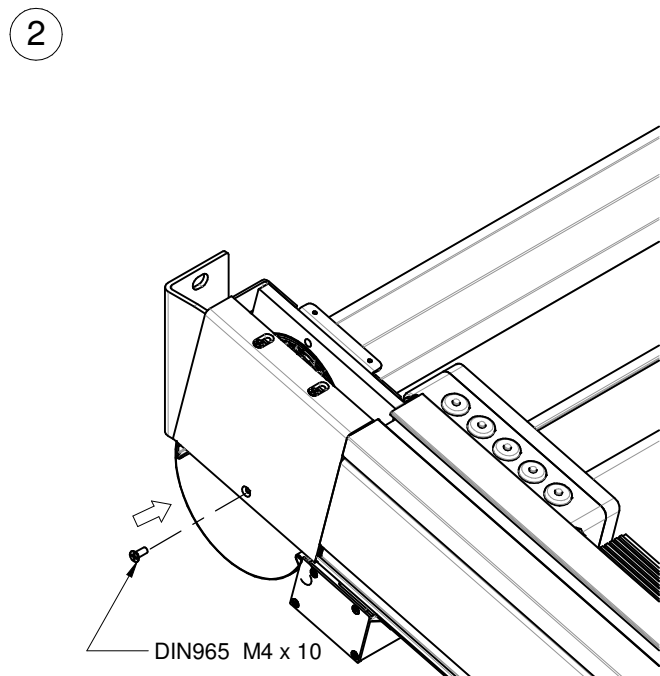
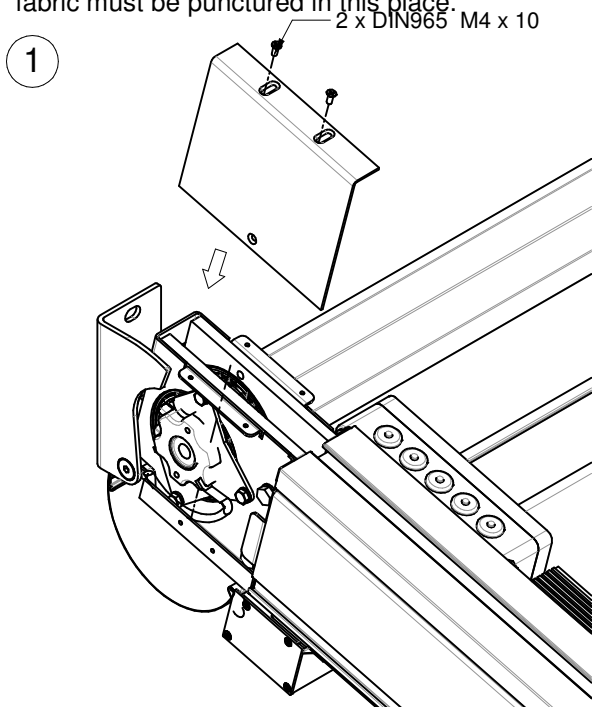



### 13.h ENDCAP HINGE

- › Fit an end cap on the end of each arm.
- › If necessary fasten the end cap on the arm with a self-tapping screw DIN7504 4.2x13.

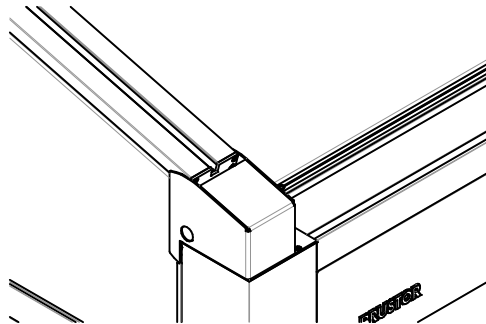
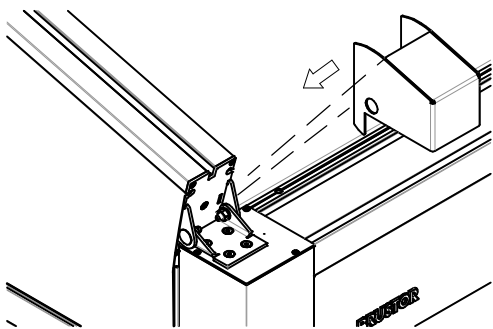

### 13.i ROOF COVERS

- › Operate the folding fabric motor and bring the folding fabric as far upwards as possible. (1)
- › Place a fixation roof cover on the inner side of all arms just past the pulled up fabric (2).
- › Position the fixation roof cover 1/8" under the top of the arm profile and fix with self-tapping screws DIN7504 Ø4.2 x 16. (3)

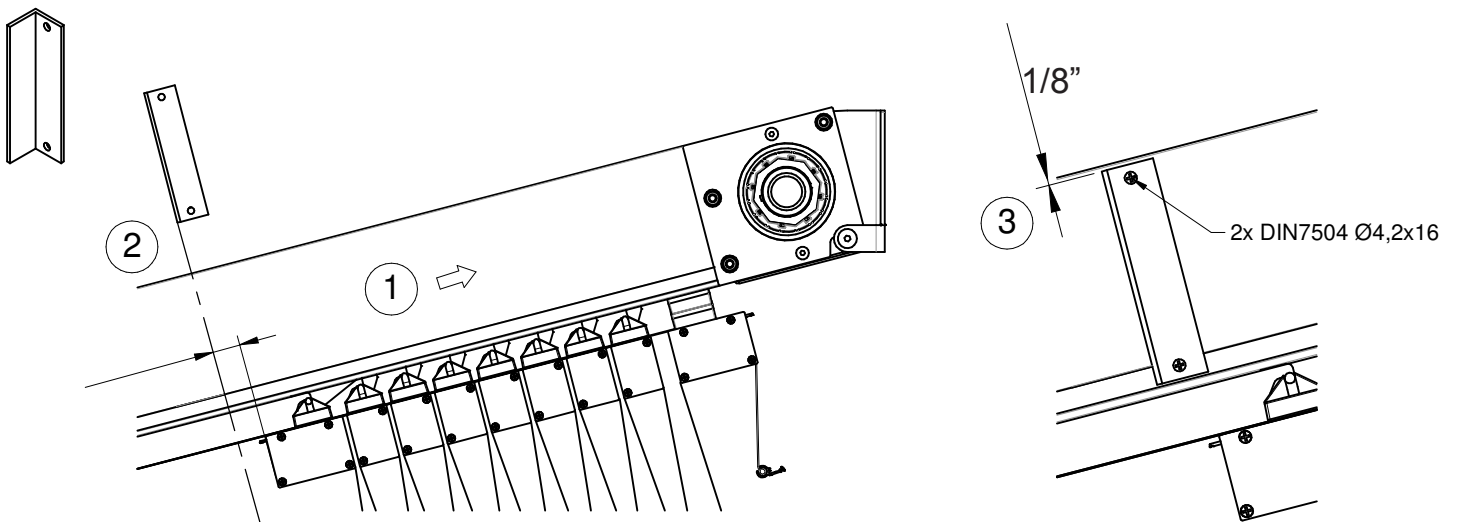

- › Position the roof cover front over the fixation roof cover and drill the holes (1).
- › Fix with screws DIN7991 M6x20 and nuts. (2)

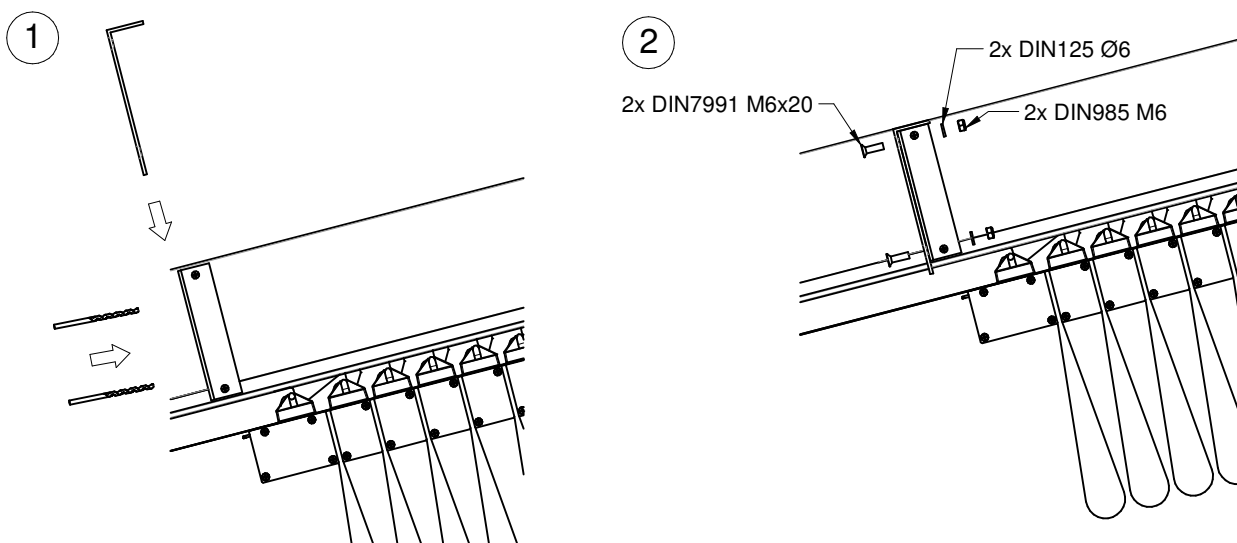

- > Position the roof cover (with cut corners) and the roof cover back.
- > Place the roof cover appr. 3/8" over the roof cover front and fasten with self-tapping screws DIN7504 Ø4.2 x 13 in the arm profile. (1) Apply a strip of silicone between the overlapping of the roof cover and the roof cover back. (2)
- > Slide the roof cover back against the wall and saw out at the level of wall brackets. Apply a continuous strip of silicone for a watertight finish. (3)
- > Also screw the roof cover back tight on the arms with self-tapping screws.
- > For a fully watertight seal between the wall and the outdoor living area, the installer must apply lead or EPDM in the wall and over the roof cover.

